

1970
TO
2025

**STORIES ABOUT
MENSTRUAL PRODUCTS
IN INDIA**



**JATAN SANSTHAN, UDAIPUR
MENSTRUAL HEALTH ACTION FOR IMPACT**



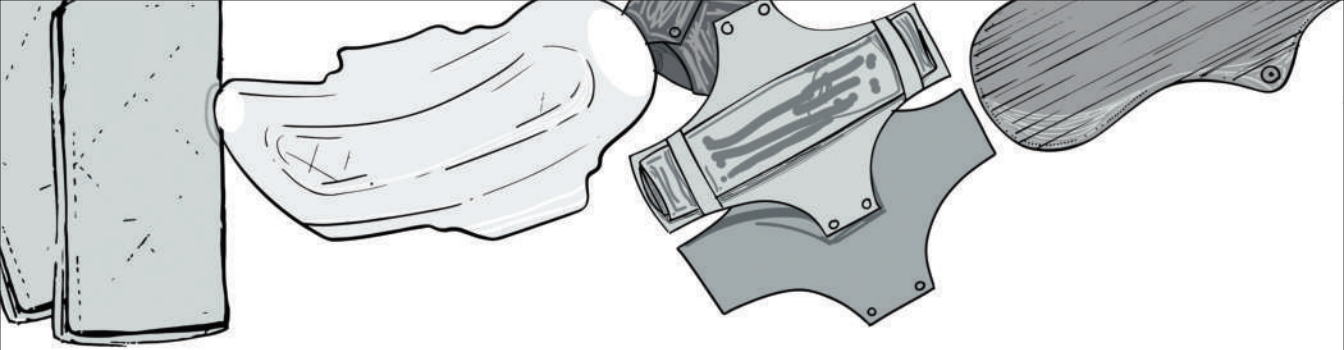

Jatan Sansthan

Jatan Sansthan is a grassroots NGO founded and registered in 2001. The core areas of our work are education, reproductive health, gender, local governance and domestic violence. Jatan takes a multifaceted and collaborative approach actively engaging with communities, supporting local ideas, questioning existing social structures and facilitating change.

The organisation works with both rural and urban population in resource poor settings in multiple districts in Rajasthan. Jatan has also facilitated menstrual health interventions pan India, in North Eastern states, Bihar, Chattisgarh, Madhya Pradesh and Jharkhand.

Menstrual Health Action for Impact (MHAi)

MHAi started in 2017 as the Menstrual Health Alliance India, bringing together ecosystem actors in India for evidence-based joint advocacy on menstrual health. In 2024, we became Menstrual Health Action for Impact, a think tank providing strategic advisory services and a convening platform to advance action on menstrual health across low- and middle-income countries.

We work across policy, product markets, health systems, and waste management to promote a rights-based, systems-oriented approach to menstrual health as a gateway for women's health, supporting governments, civil society, and private sector actors to improve access to information, products, and services for people who menstruate across LMICs.

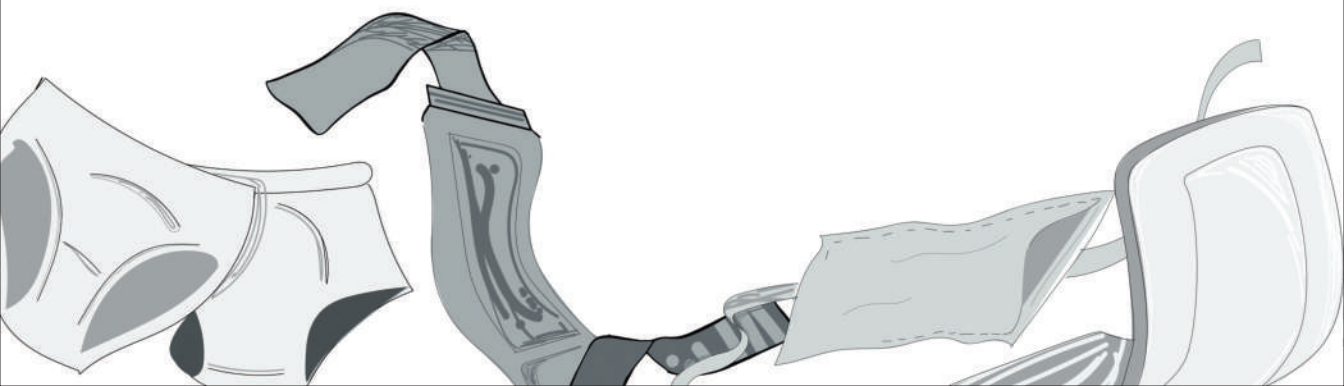

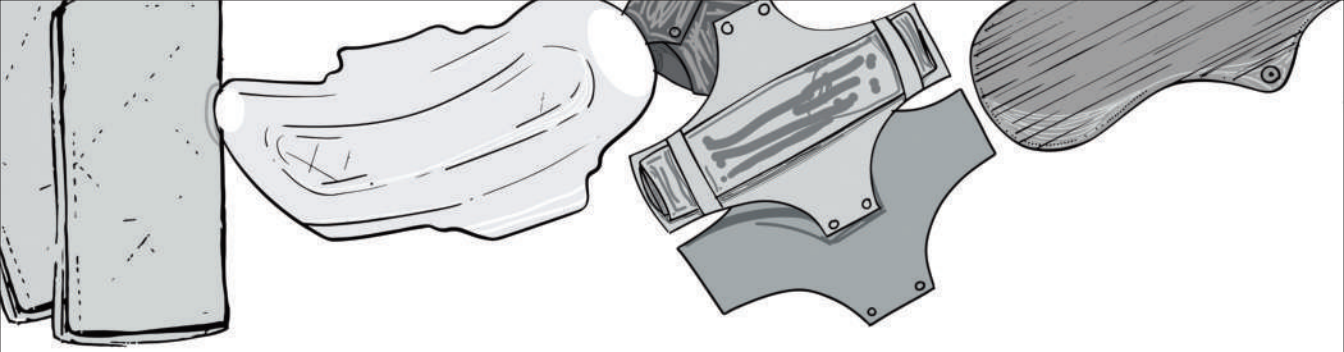

FOREWORD

Three decades ago, back in 90s - if you asked about the best menstrual product in India, one would get stares, there would be shame, a deep silence around the topic and embarrassment.

Two decades ago, small but meaningful changes began taking shape. People started recognising need for safer menstrual products.

A decade ago, if you asked about the best menstrual product in India, the immediate answer would be - menstrual pads. Today, in 2025, many people still feel that disposable menstrual pads are the go-to item during periods - convenient and widely available. Yet, you will meet people in your social circles, professional networks, and during field work, who talk about how reusable menstrual products have been liberating for them - socially and financially, or how environmental concerns have made them rethink their choice of period products. Sanitary pads are not the only aspirational product in the Indian period product market anymore - menstrual cups, reusable pads and menstrual underwear are

establishing their place, and carving out their space in this highly competitive and rapidly evolving period product landscape.

The period product landscape in India is one of the richest in the world, and it's a landscape that is growing and diversifying. While disposable sanitary pads capture a large part of the market (Proctor and Gamble alone have 85%+ of the market for commercial products in India), we have seen products like the menstrual cup gain popularity in the past few years. India's vast population and the diverse needs of the population is a good reason to have a diverse market for period products. India has 393 million girls and women of reproductive age who need menstrual products on a regular basis. There are also people with disabilities, with gender diverse identities, and those who experience temporary or long-term displacement who have unique menstrual needs, including menstrual product requirements.

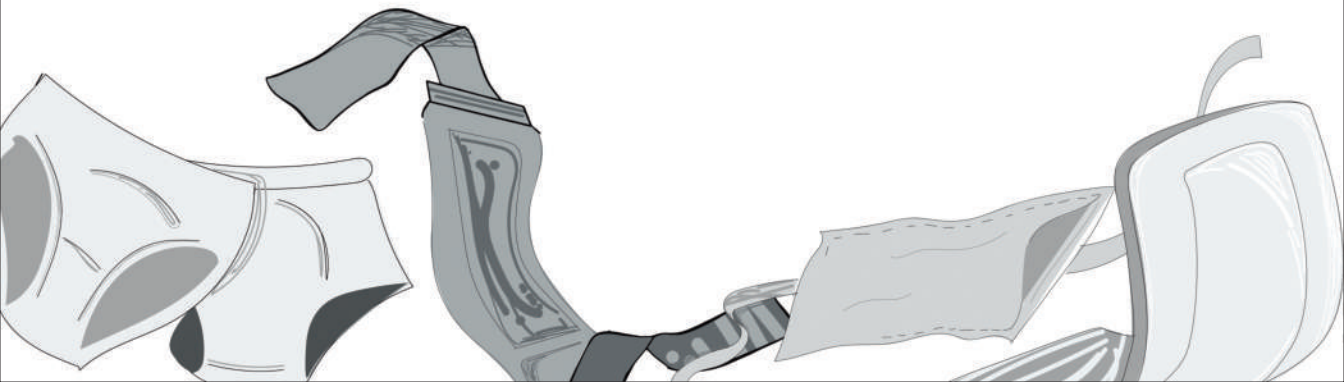

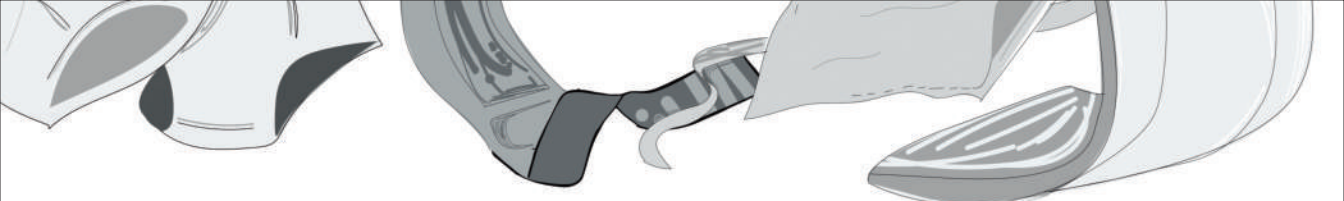

What do we know about India's menstrual products? How and why has the landscape evolved? What is so diverse about the period product landscape? What are the innovations, and what needs do they meet, and why do they matter?

This graphic novel traces the history of period product enterprises in India, over a 40 year period. It is by no means exhaustive, and meant to be indicative of the thinking, motivations, innovations, and journeys of individuals, organisations and companies who sought to address a significant barrier to health for millions of girls and women through these products. For some the product was or is the end game, for others, a part of a comprehensive approach to enable good menstrual health and hygiene for all.

This graphic novel acknowledges that the period product landscape is more diverse than is represented here. Not every company or entrepreneur is captured. We present some social enterprises (both for-profit and not for profit) to tell the story of the evolution of period products in India over the last four decades, seeking to highlight how people's needs were understood and responded to.

**ARUNDATI MURLIDHARAN
TANYA MAHAJAN**

Founders
Menstrual Health Action
for Impact

The narratives of each enterprise or organization in this graphic novel gives us valuable insights into period product needs, aspirations, ability and willingness to pay. Each narrative contributes towards important lessons for the period product market and "users".

The graphic novel celebrates innovation, inclusion and representation, evidence, and community voices. It celebrates trail blazers who took bold steps to talk about periods when it was not acceptable, and those who continue to break the silence through their innovative offerings.

For us, choice is central, and we hope to use this graphic novel, to emphasize and reiterate that every person who menstruates must have a choice of the products he/she/they want to use, with appropriate and correct information and support. We acknowledge Twisha Mehta, for her pivotal contribution to tell this story and we thank all our collaborators.

Design and Research Team:

Khushbu Solanki,
Navyaa Shah,
Shuchi Mehta,
Spurthi Kolipaka,
Tejaswy Swathi Kovuri,
Tia Alex,
Urvi Medhi.

**KAILASH BRIJWASI
LAKSHMI MURTHY**

Founders
Jatan Sansthan



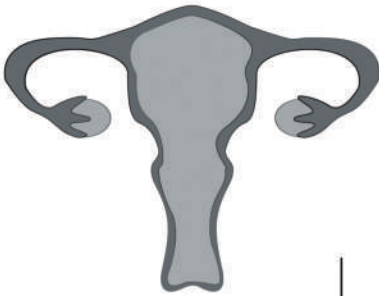

CLOTH

MENSTRUAL
HUT

SAND/
ASH PAD

1970

ECOFEMME

ANANDI

ADRIA

JAYSHREE

WASHABLE
CLOTH PADS

COMPOSTABLE AND
BIODEGRADABLE
PADS

PERIOD PANTY

PAD PRODUCTION
UNIT FOR SHG

2010

2010

2009

2006

UGER

TIMEPIECE

SHE CUP

WASHABLE
CLOTH
PADS

LAL KAPDA -
REUSABLE
CLOTH

MENSTRUAL
CUP

2010

2010

2010

2010

2014

NOTE: THIS GRAPHIC NOVEL ACKNOWLEDGES THAT THE PERIOD PRODUCT LANDSCAPE IS MORE DIVERSE THAN IS REPRESENTED HERE. NUMEROUS OTHER PRODUCTS HAVE SPARKED EVOLUTION AND IMPROVEMENT IN THIS SPACE; HOWEVER, DUE TO TIME AND BUDGET CONSTRAINTS, WE COULD NOT COVER THEM ALL.

WE PLAN TO ADD DETAILED SPREADS FOR THESE ORGANISATIONS AS AND WHEN WE CONNECT WITH THEIR FOUNDERS AND LEARN MORE ABOUT THEIR JOURNEYS.

2024

2023

2022

2021

eline

BANDAGE
PAD

BELTED
PAD

CRUSHED
NEWSPAPER

PAD WITH
STICK ON

WINGED
PAD

1980

GOONJ

VIKALP

SAHYOG

UPCYCLED
CLOTH PAD -
MY PAD KITS

LACE-WALAA
KAPDA

WOOD ASH
PAD

2006

2000

2000

1999

1990

SAATHI

BOONDH

SAUKYAM

SOCH
GREEN

BANANA FIBRE
PADS

MENSTRUAL
CUPS

BANANA FIBRE
PADS

LABIAL
PADS

2015

2016

2017

2017

2017

2020

2019

2018

CLOTH

Menstruators harvested cloth from fabrics available at home. These pieces of textiles were washed and reused until it was no longer fit to absorb any menstrual discharge.



CRUSHED NEWSPAPER

A sheet of newspaper was crushed. This was placed into a piece of cloth and folded into the shape of a pad.



SAND/ASH PAD

In some regions in the country, women made cloth bags and filled it with locally available sand or ash. These worked as absorbents.

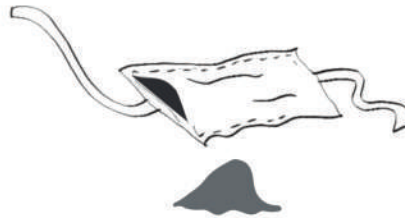

This decade was witness to different ways menstruators managed their periods.

Cloth was predominantly used across the country, by both rural and urban menstruators. Isolating oneself during periods was common practice.

1970

MENSTRUAL HUT

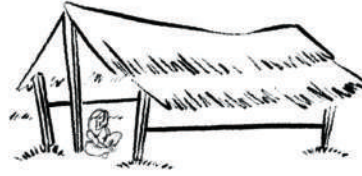

Menstruators stayed in menstrual huts outside the village or in cow sheds for the whole length of their periods, bleeding directly on to their ghagras (skirts) or saris.



BANDAGE PAD



Branded pads with names such as Comfit Pads and Angela pads were available. These pads had a core of wood pulp covered by a cotton bandage. The ends had loops. The user fixed the pad in place with the help of drawstrings.



BELTED PAD

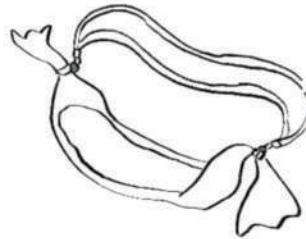

During this time, Johnson and Johnson came up with belted pads under the brand name of Carefree.



Branded disposable sanitary napkins were available at pharmacies in the metro cities. By the 80's kirana few stores had begun to carry disposable pads.

1980



STILL
IN
USE

Many practices continued.
However, this decade saw change
in the design of commercially
available disposal pads.

1980

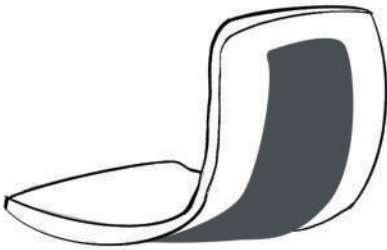

STICK ON PAD



PAD WITH WINGS

The belted disposable pads continued to be popular. The disposable pads that could be stuck on to the crotch of the underwear began to be available in the market.

This decade also witnessed the emergence of stick on winged pads.

1990



Up until now, the management of menstruation was a personal matter, rarely discussed outside a home.

Non Government Organisations and foundations began discussions around women's reproductive health.

1990



SAHAYOG DESIGN

For the first time aspects of menstruation slowly entered the public space. The first was NGO Sahayog followed by design studio Vikalp Design.

SAHAYOG, a non-profit voluntary organization, was started in 1992. SAHAYOG was founded as a Society in Almora, but relocated to Lucknow in 2000, with a defined vision of working on Sexual and Reproductive Health Rights of women and youth.

<https://www.sahayogindia.org/>

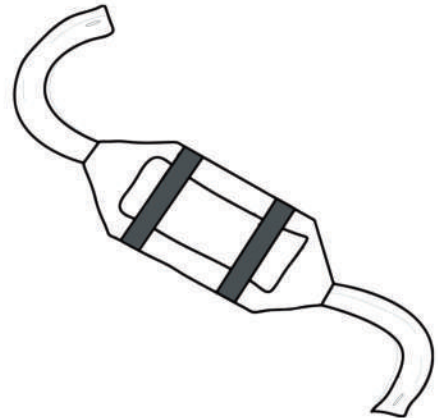

VIKALP DESIGN

Vikalp design, a design studio, located at Udaipur in Rajasthan was founded by Lakshmi Murthy in 1988.

The studio has developed culturally appropriate products for communicating for reproductive health, menstrual health and gender.

Vikalp Design's work was moved to into Jatan Sansthan, an NGO, in 2016.

<https://vikalpdesign.com> and
<https://jatansansthan.org/>

2000

SAHAYOG 1999

JAGESHWAR, ALMORA

Uttarakhand (then UP)



अल्मोरा
ALMORA

DR. ABHIJIT DAS
AND HIS TEAM
WERE WORKING
WITH WOMEN IN
ALMORA.

THEY FOUND THAT
WOMEN WERE COMPLETELY
RESTRICTED DURING THEIR
PERIODS.





MENSTRUATION WAS
REFERRED TO AS
"ALAG HONA"
(BEING SEPARATE)



WHEN WE STARTED WORKING WITH
THE COMMUNITY, WE REALISED
THAT SOME WOMEN WOULD BE
SITTING SEPARATELY.

WOMEN STAYED IN A COW SHED
FOR THE ENTIRE LENGTH OF
THEIR PERIOD, WITHOUT
CHANGING THEIR CLOTHES.



THEY SAT ON
FLAGSTONES OR A
JUTE SACKING AND
BLED ONTO THEIR
GHAGRAS OR
SKIRTS

YOUNGER WOMEN USED
NYLON HALF-PANTS
(TIGHT SHORTS)



I AM KEPT ISOLATED AT THIS TIME, EVERYONE IN
THE VILLAGE KNOWS I HAVE MY PERIOD. NO ONE
COMES NEAR ME BECAUSE I SMELL. I AM
CONSIDERED POLLUTED.

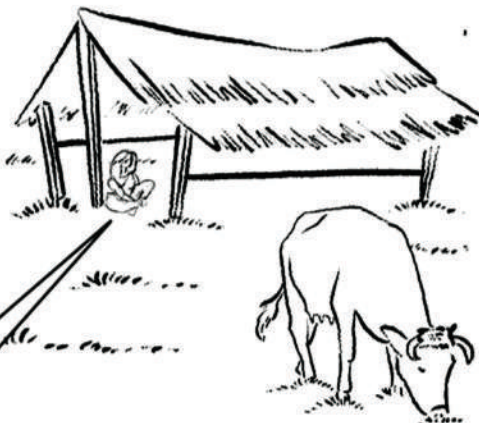

WHILE DISCUSSING POSSIBLE
INTERVENTIONS, SAHAYOG WAS
LOOKING TO ADDRESS SOME
ASPECTS -

UNDERSTANDING
MENSTRUATION

DISCRETION

MAINTAINING
HYGIENE

WOMEN'S OWN
CONTROL OVER
MENSTRUATION



"THE RIGHT TO MENSTRUATE WITH DIGNITY"

SAHAYOG'S INTERVENTION WAS TO RAISE AWARENESS THAT PERIOD BLOOD WAS NOT POLLUTED. THE ISSUE OF SMELL WAS ALSO ADDRESSED. THEY HELPED WOMEN TO RATIONALISE THAT SMELL WILL OCCUR IF MENSTRUAL CLOTH IS NOT CHANGED BY ASKING THEM QUESTIONS.



TAKING INSPIRATION FROM A GROUP IN BIHAR, SAHAYOG BEGAN EXPERIMENTING WITH WOOD ASH AS A MENSTRUAL ABSORBENT.

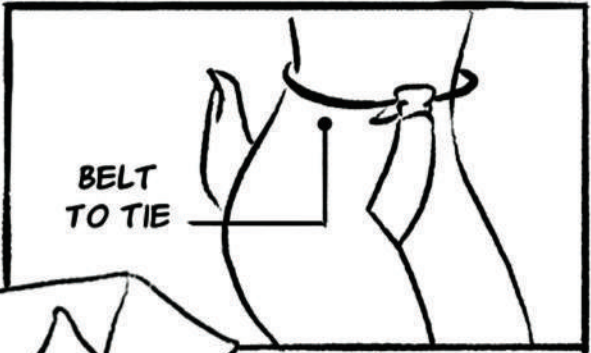
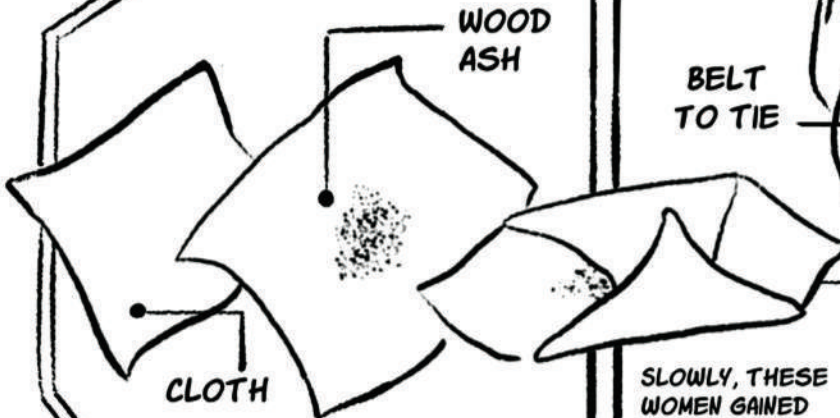

THE DESIGN OF THE SANITARY PAD WAS SIFTED WOOD ASH WRAPPED IN A CLOTH.



WHY WOOD ASH?

READILY AVAILABLE ✓

ABSORBS ODOURS ✓

COMPLETELY BURNT, SO STERILE ✓

CATCHES THE PIGMENT HENCE REDUCING STAIN MARKS ON CLOTH ✓

EASY TO THROW INTO WOODS OR FIELDS AFTER BEING USED ✓

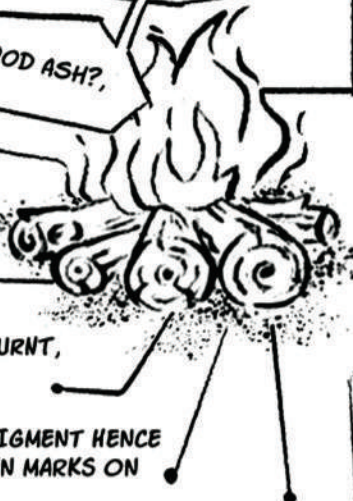

SLOWLY, THESE WOMEN GAINED SOME CONTROL OVER THEIR MOBILITY. BY WEARING THE PAD, THEY WERE ABLE TO MOVE AROUND AND CONCEAL THAT THEY WERE MENSTRUATING.



THEY HAD A PRODUCT MADE OF VERY SIMPLE MATERIALS COMPLETELY WITHIN THEIR ACCESS AND CONTROL.

BACK IN 1999, IT WAS NOT EASY TO WORK WITH YOUNG WOMEN AS THEY WERE CLOSELY SUPERVISED BY THEIR MOTHERS-IN-LAW. HOWEVER, SAHAYOG MADE A REMARKABLE START.



VIKALP DESIGN 2000

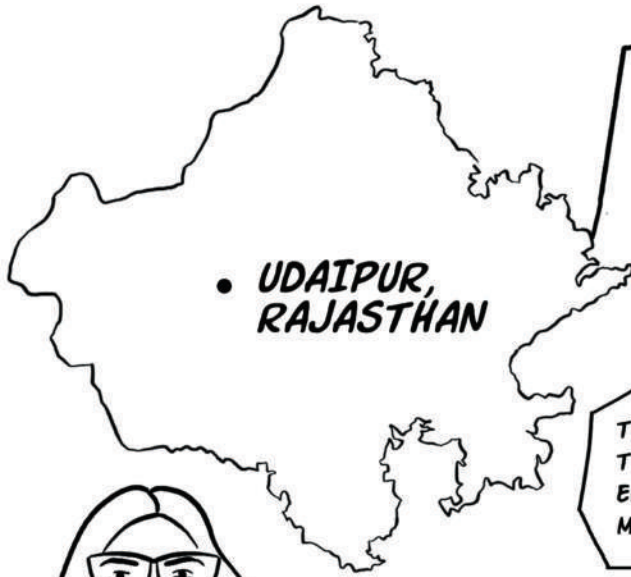

HEY, YOU DESIGNERS
DON'T MAKE ANYTHING
FOR WOMEN'S
REPRODUCTIVE
HEALTH!

THE STATEMENT ABOVE SERVED AS A
TRIGGER FOR LAKSHMI MURTHY TO
EMBARK ON HER RESEARCH IN THE
MENSTRUAL HEALTH MANAGEMENT SPACE.



I ENGAGED IN FIELDWORK AND
AFTER MANY CONVERSATIONS
WITH YOUNG ADOLESCENTS,
I LEARNED THAT COTTON CLOTH,
WAS COMMONLY USED AS A
MENSTRUAL ABSORBENT.

WE DO NOT WEAR AN
UNDERWEAR - SO WE
TIE A STRING AROUND
OUR WAIST AND TUCK
OUR CLOTH IN PLACE.
SOMETIMES, WE ALSO
TUCK IT INTO THE
GHAGRA DRAWSTRING.



BAI, I HAVE
STARTED MY
PERIOD.

DON'T
WORRY,
TAKE THIS
CLOTH.



CLOTH WAS TYPICALLY HARVESTED FROM PREVIOUSLY USED TURBANS,
GHAGRAS (SKIRTS), DUPATTAS (VEILS/SCARFS), PETTICOATS AND
MEN'S BANIYAN (VESTS). THE CLOTH SELECTED WAS ALWAYS DARK - SO
THAT BLOOD STAINS WOULD NOT BE VISIBLE.

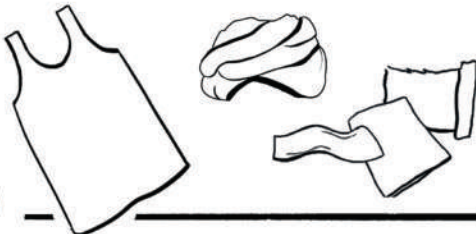

AROUND THIS TIME
VIKALPDESIGN WAS ALSO
CONDUCTING MULTIPLE
REPRODUCTIVE HEALTH
TRAINING PROGRAMS AS A
PART OF LAKSHMI'S
FELLOWSHIP*. AN IMPORTANT
MESSAGE WAS ALWAYS
COMMUNICATED TO
ADOLESCENT GIRLS -
"USE WHITE OR LIGHT
COLOURED CLOTH DURING
PERIODS, AS YOU NEED TO
SEE THE COLOUR OF YOUR
DISCHARGE**".

*MACARTHUR FUND FOR LEADERSHIP
DEVELOPMENT - 2000 TO 2003

** GREEN, YELLOW AND PINK DISCHARGE
IS INDICATIVE OF INFECTIONS

AT REPRODUCTIVE HEALTH TRAINING SESSIONS WITH RURAL GIRLS, SHE INCLUDED COMMUNICATION ON COLOUR OF CLOTH AND THE IMPORTANCE OF HANGING CLOTH DIRECTLY UNDER THE SUN.

TO REINFORCE THE MESSAGE, THE "LACE WALA KAPDA" (CLOTH WITH STRAPS) WAS DEVELOPED.

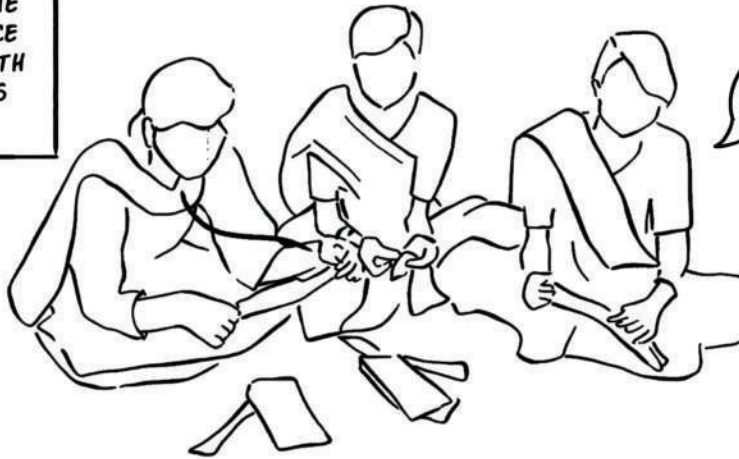

DIDI I WE HAVE HEARD MEN WILL GO BLIND IF THEY SEE A MENSTRUAL CLOTH.

GIRLS WERE TAUGHT TO STITCH THEIR OWN LACE WALAH KAPDA

THESE INTERVENTIONS WERE REVOLUTIONARY AT THAT TIME IN CONSERVATIVE RAJASTHAN

STRAPS HOLDING DOWN WHITE CLOTH

LOWER COLOURED CLOTH

WHITE/ CREAM CLOTH TO UNDERSTAND COLOUR AND CHARACTER OF DISCHARGE

HOLD-UP STRAPS



TRAINING AIDS WERE DESIGNED FOR FACILITATORS. SUNDARI, A CARDBOARD DOLL WAS CENTRAL TO THIS INITIATIVE. ADOLESCENT GIRLS COULD MAKE SUNDARI WEAR THE LACE WALAH KAPDA, PRACTICING PAD WEARING.



THIS BECAME THE START OF A MENSTRUAL HEALTH AND HYGIENE MOVEMENT.



2000

Menstrual health and hygiene issues started to gain momentum with independent activists and organisations providing practical solutions to manage menstruation efficiently.

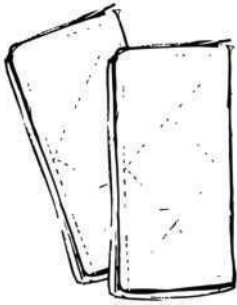

GOONJ

New Delhi
<https://goonj.org>



ADIRA

Bengaluru, Karnataka
<https://myadira.com/>

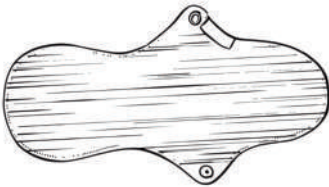

ECOFEMME

Auroville, Tamil Nadu
<https://ecofemme.org>

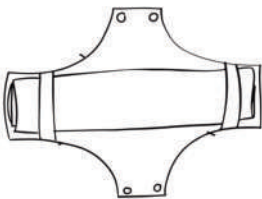

UGER PAD

Udaipur, Rajasthan
<https://jatansansthan.org/menstrual-health-and-uger-cloth-pads/>

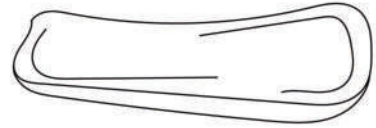

JAYA SHREE INDUSTRIES

Coimbatore, Tamil Nadu
https://en.wikipedia.org/wiki/Arunachalam_-_Muruganantham



ANANDI PADS

Navi Mumbai, Maharashtra
<https://www.aakarinnovations.com>



TIMEPIECE

Local Markets, Gujarat, Rajasthan, Bihar, Madhya Pradesh and other states

2010

GOONJ 2005

DELHI

THE TRIGGER - FOUNDER ANSHU AND MEENAKSHI GUPTA REALISED THAT OUT OF THE 3 BASIC NEEDS OF HUMAN KIND - ROTI, KAPDA, MAKAN (FOOD, CLOTHING, SHELTER) - CLOTHING WAS OFTEN THE MOST IGNORED.

GOONJ WORKERS VOLUNTEERING DURING THE TSUNAMI CATASTROPHE IN TAMIL NADU IN 2005, FOUND HUGE AMOUNTS OF DONATED CLOTHING LYING ABANDONED.

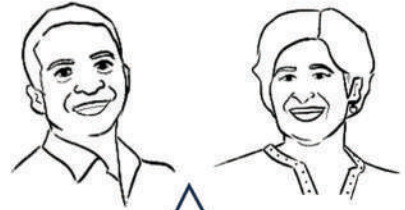

WE REALISED THIS "WASTE" COULD BE PUT TO GOOD USE, THE GARMENTS COULD BE TURNED INTO AN IMPORTANT RESOURCE FOR RURAL COMMUNITIES.

40 WOMEN FROM SLUMS NEAR THE TSUNAMI STRUCK AREAS BEGAN THE MAMMOTH TASK OF SORTING CLOTHS THROUGH CLOTH PILES. THEY TOOK UP THE TASK OF CHANNELIZING MORE THAN 100 TRUCKS OF THIS MATERIAL TO PEOPLE IN NEED.

DURING THIS EXERCISE, WOMEN REALISED THAT CLOTH PADS COULD BE MADE FROM THESE GARMENTS.

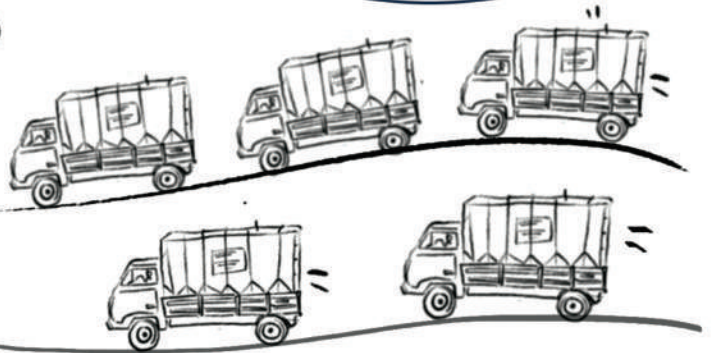

THE WOMEN FIRST USED VARIOUS SAMPLES ON THEMSELVES. THE DIMENSIONS OF THE PAD EVOLVED FROM THIS SMALL PRACTICAL LAB.

THE NEED FOR UNDERWEAR WAS SOON REALISED, AS THE PADS COULD BE WORN ONLY WITH AN UNDERWEAR.

GOONJ STARTED MAKING UNDERGARMENTS REPURPOSING T-SHIRTS, OTHER HOSIERY ITEMS AND OTHER GARMENTS.

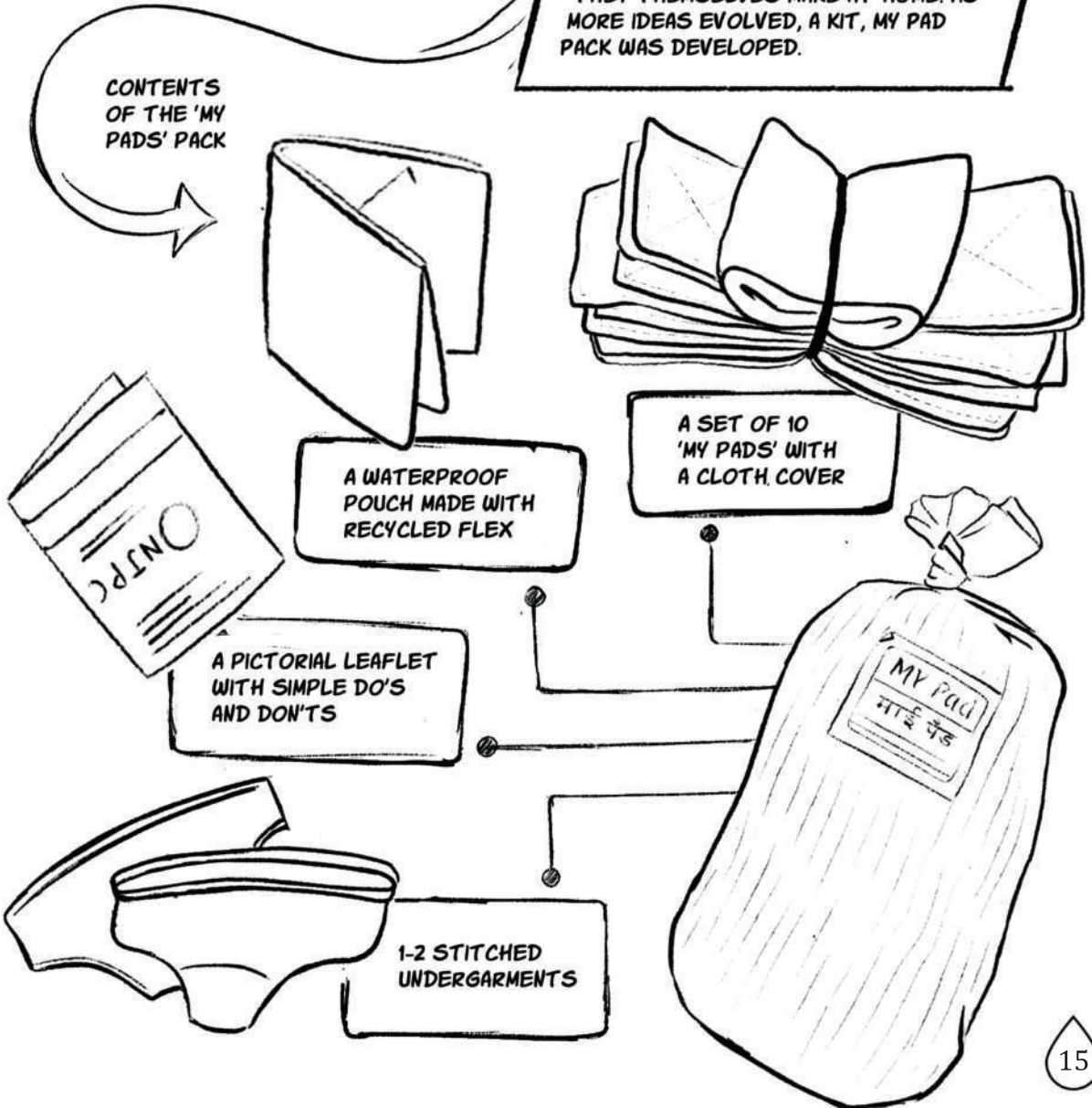
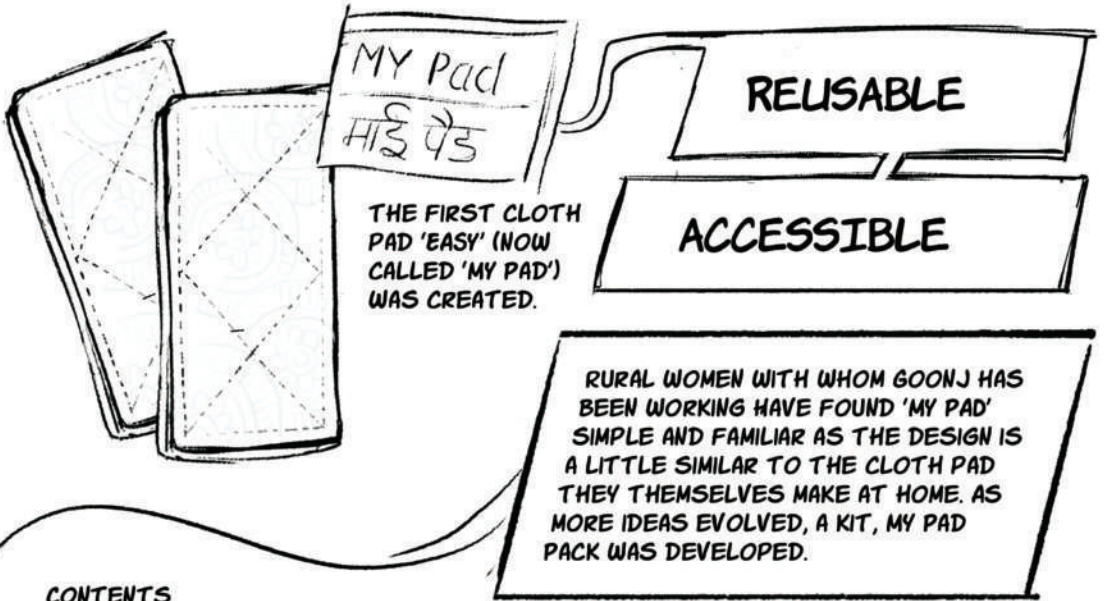

JAYASHREE INDUSTRIES 2006



ONE DAY IN 1998, ARUNACHALAM MURUGUNATHAM WAS RESTING AT HIS HOME. HIS WIFE SHANTI PASSED BY- HIDING SOMETHING BEHIND HER BACK



SHANTI, WHY DON'T YOU USE SANITARY NAPKINS LIKE THEY SHOW ON TV?

MURUGANATHAN WAS SO TROUBLED, THAT ON THE SAME DAY HE WENT TO THE STORE TO BUY HER SANITARY NAPKINS.

THE NAPKINS WEIGHED 10 GRAMS EACH. BUT 10 GRAMS OF COTTON ONLY COSTS 10 PAISE. THESE MULTINATIONALS ARE SELLING ONE PAD FOR RS. 4.

IF I START USING SANITARY NAPKINS,

WE WILL HAVE TO CUT OUR FAMILY MILK BUDGET,

MAY BE EVEN ON OTHER GROCERIES



THIS IS NOT FAIR! ARE THERE NO CHEAPER PADS?



NOTE: THIS SPREAD IS BASED ON PUBLICLY AVAILABLE INFORMATION AND IS YET TO BE VETTED BY THE ORGANISATION'S FOUNDERS

VERY DISTURBED, MURUGUNATHAM DECIDED THAT IT IS HIGH TIME SOMEONE DID SOMETHING ABOUT THE COST - SO HE HAD A NEW GOAL - DESIGNING A LOW-COST PAD!



HE DESIGNED PADS AND NEEDED VOLUNTEERS TO TEST HIS PROTOTYPES. HE APPROACHED HIS WIFE, SISTERS AND MEDICAL COLLEGE GIRLS.

HE SOON REALISED THE MACHINE USED TO PRODUCE PADS WAS VERY EXPENSIVE.

HE ALSO REALIZED THAT THE CORE OF THE PAD WAS NOT COTTON AS HE HAD THOUGHT, BUT WOOD PULP.

YOU HAVE BECOME MAD, DON'T TALK TO ME. I AM LEAVING, YOU CAN DO THESE EXPERIMENTS ON YOUR OWN. DON'T INVOLVE ME. ALREADY EVERYONE IS MAKING FUN OF YOU.



FOOTBALL BLADDER



UNDETERRED, MURUGANATHAN DECIDED TO EXPERIMENT ON HIMSELF. HE TOOK A FOOTBALL BLADDER FILLED WITH ANIMAL BLOOD. HE WORE THE PAD AND CONNECTED A TUBE TO THE FOOTBALL BLADDER AND DIRECTED THE FLOW TO THE PAD TO TEST HOW IT FUNCTIONED.

ANIMAL BLOOD STAINS - SIMULATED PERIODS

HE DEVELOPED A SMALL DE-FIBERATION UNIT, A CORE FORMING UNIT, A SEALING UNIT AND AN ULTRA VIOLET SANITIZING UNIT. IN 2006, HE SHOWED HIS IDEA AT IIT MADRAS, REGISTERED HIS INVENTION FOR THE NATIONAL INNOVATION FOUNDATION'S GRASSROOTS TECHNOLOGICAL INNOVATIONS AWARD AND WON IT. HE OBTAINED SEED FUNDING AND FOUNDED JAYAASHREE INDUSTRIES.

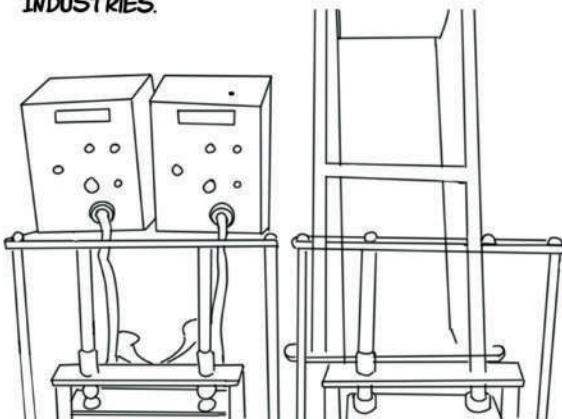

HE SUPPLIED THESE MACHINES AND RAW MATERIALS TO SHG GROUPS PAN INDIA. HE SET THE PRODUCTION RATE FOR MANUALLY OPERATED MACHINES AT 900 TO 1000 NAPKINS PER DAY AND THE SEMI-AUTOMATIC MACHINE FOR 3000 NAPKINS PER DAY

HE PUT IN **4.5 YEARS** OF RESEARCH.

HE WAS SUCCESSFUL IN REDUCING THE OVERALL COST OF THE PADS.

- WOOD FIBER
- THERMO BONDED NON-WOVEN
- POLYETHYLENE - BARRIER FILM,
- RELEASE PAPER
- SUPER BOND PASTE +AMP; LDPE (LOW DENSITY POLYETHYLENE)

- WITH A 50 GSM THICKNESS : PACKING COVER.



I AM FINALLY SATISFIED. I HAVE MANAGED TO MAKE WOMEN'S LIFE EASIER!

ADIRA 2009



BANGALORE

Karnataka

ADIRA (YASHRAM HOUSE OF BRANDS) WAS FOUNDED BY DEEPA KUMAR. SHE WAS PASSIONATE ABOUT CREATING PRODUCTS THAT BOOST COMFORT AND CONFIDENCE FOR WOMEN AND GIRLS



THE COMPANY HOLDS PATENTS IN BOTH USA AND INDIA WHICH WAS FINALLY GRANTED IN 2019 - AFTER FULL 10 YEARS POST APPLICATION.. SOON AFTER, MULTIPLE LARGE AND SMALL COMPANIES EMERGED AS INFRINGERS. SHE MENTIONED THAT GUARDING THIS STATUTORY RIGHT BECAME IMMENSELY DRAINING, HOWEVER SHE SAYS IT IS WORTH THE FIGHT.



INTELLECTUAL
PROPERTY INDIA

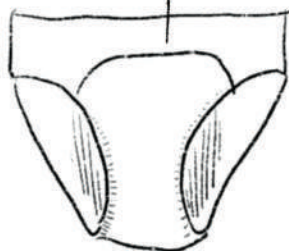
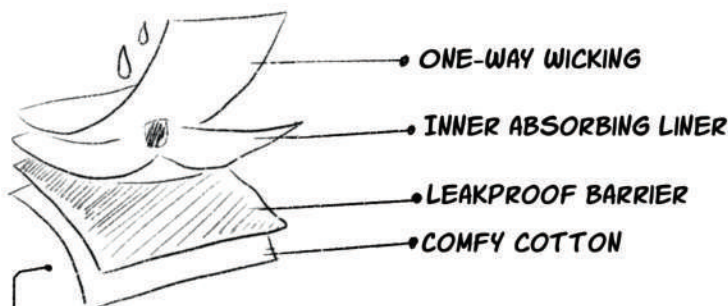

THE GARMENT USES A HI-TECH FABRIC WITH LAYERS FOR ONE-WAY WICKING AND A LEAKPROOF BARRIER. IT CONTAINS A BUILT-IN LEAK-PROOF LAYER WITH POLYURETHANE LAMINATE.

NOTE: THIS SPREAD IS BASED ON PUBLICLY AVAILABLE INFORMATION AND IS YET TO BE VETTED BY THE ORGANISATION'S FOUNDERS



THIS LEAKPROOF CROTCH SUPPORTS THE PAD AND PREVENTS STAINS. THE TECHNOLOGY IS ANTI-SEEPING AND RAPID DRY, AND IS DESIGNED TO HOLD HEAVY FLOW

LEAKPROOF CROTCH PREVENTS STAINS

SUPPORT PATCH TO PAD AND TO KEEP IT IN PLACE



THE DESIGN IS MEANT TO BE HYGIENIC AND WAS DEVELOPED FOR ALL BODY TYPES, INCLUDING SIZES TILL 10XL.

HIP

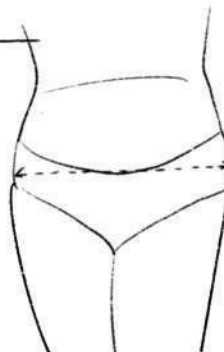

SIZE	HIP (cm)
3XL	43-45
4XL	45-47
5XL	47-49
and so on	
till 10XL	

ADIRA HAS RANGE OF PRODUCTS THAT ARE OF VARIOUS SIZE AND AGE-INCLUSIVE, INNER WEAR FOR ALL LIFE STATES, RANGING FROM TEENS, MATERNITY/POSTPARTUM PRODUCTS AND INCONTINENCE BRIEFS DESIGNED TO ABSORB UP TO 25ML OF LIGHT LEAKS.

ANANDI PADS 2010

AAKAR INNOVATIONS PVT. LTD.



AS A COLLEGE PROJECT, JAYDEEP MANDAL INITIATED THE PRODUCTION OF SANITARY PADS IN 2010. DURING HIS WORK, HE INTERACTED WITH WOMEN IN VILLAGES AND GOVERNMENT DOCTORS IN UTTARAKHAND. HE FOUND THAT THERE WERE MANY FACTORS THAT AFFECT WOMEN'S HEALTH.



LIMITED ACCESS TO
SANITARY PADS

HEALTH CHALLENGES
ARISING FROM UNHYGIENIC
PRACTICES DURING PERIODS

PERVASIVE LACK OF
AWARENESS
SURROUNDING
MENSTRUAL HYGIENE



TO ADDRESS THESE ISSUES, HE STARTED TRAINING PROGRAMS FOR LOCAL WOMEN, EQUIPPING THEM WITH THE SKILLS TO PRODUCE PADS, WHILE ALSO RAISING AWARENESS ABOUT MENSTRUAL HYGIENE.

JAYDEEP, WHILE WORKING IN AFGHANISTAN DURING AN MMH STUDY, RECOGNIZED THE CHALLENGES POSED BY PLASTIC DISPOSABLE SANITARY NAPKINS. MOTIVATED, HE LOOKED FOR SOLUTIONS, WHICH LEAD TO THE DEVELOPMENT OF COMPOSTABLE PADS IN THE YEAR 2012.

आकार

AFTER EXTENSIVE RESEARCH ON MATERIALS AND MACHINERY, IN 2013, AAKAR LAUNCHED ANANDI PADS.

AAKAR FOCUSED ON RAW MATERIALS LIKE JUTE, BAGASSE, BANANA FIBRE, WATER HYACINTH, BAMBOO AND COTTON.



COTTON

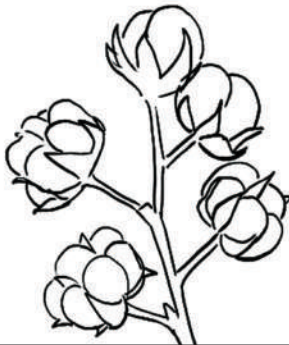

BAGASSE

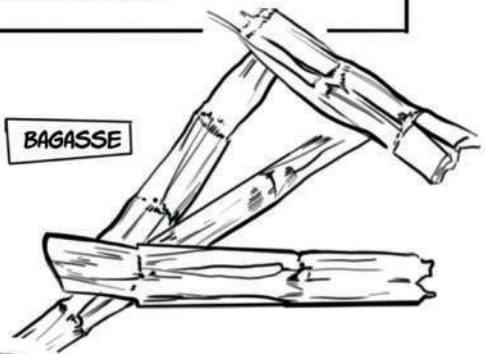

BANANA FIBRE

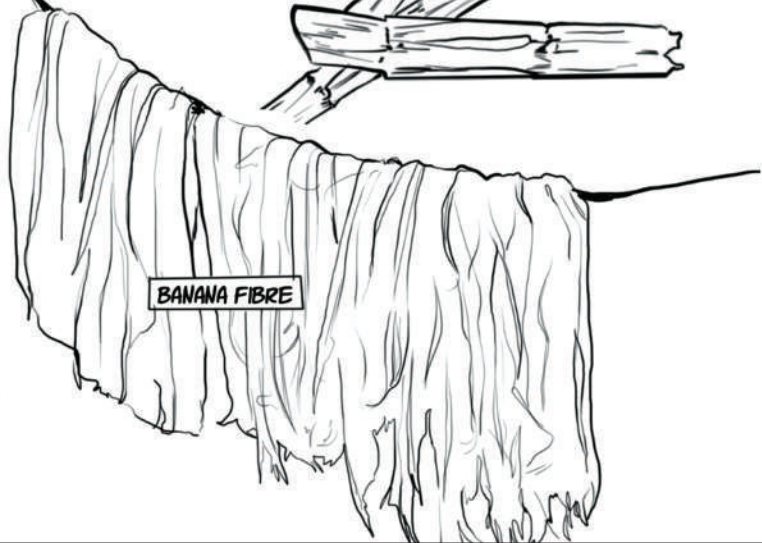

IN A COLLABORATIVE EFFORT, AAKAR ALONG WITH IJIRA (INDIAN JUTE INDUSTRIES RESEARCH ASSOCIATION) AND IIT KHARAGPUR DEVELOPED PADS WITH A JUTE ABSORBENT USING AAKAR'S MACHINERY AND TECHNOLOGY.

THIS PARTNERSHIP LED TO THE ESTABLISHMENT OF THE FIRST JUTE-BASED PAD PRODUCTION UNIT AT THE IJIRA FACILITY. AAKAR IN PARTNERSHIP WITH ENTREPRENEURS, NGOS, GOVERNMENTS ADOPTED A DECENTRALISED MODEL FOR ANANDI PAD PRODUCTION USING BOTH AAKAR'S MANUAL AND SEMI-AUTOMATIC MACHINES.



BIO-SAP FOR SUPERIOR ABSORBENCY



TOP LAYER

GOTS (GLOBAL ORGANIC TEXTILE STANDARD) CERTIFIED 100% ORGANIC COTTON

BOTTOM LAYER

COMPOSTABLE BIOPLASTIC, BREATHABLE AND HELPS IN AIR CIRCULATION LEADING TO COMFORT DURING PERIODS ENSURING SKIN SAFETY AND A RASH-FREE EXPERIENCE.

I'VE USED ANANDI PADS. IT OFFERS REMARKABLE SOFTNESS, COMFORT, AND BREATHABILITY, ENSURING A RASH-FREE EXPERIENCE AND SKIN SAFETY.

ANANDI WAS INDIA'S FIRST + ONLY CERTIFIED ~ 100% COMPOSTABLE + BIODEGRADABLE SANITARY PAD AS PER ISO-17088 (INTERNATIONAL ORGANIZATION FOR STANDARDIZATION) ANANDI PADS TURN TO COMPOST WITHIN 90-180 DAYS UNDER COMPOSTING CONDITIONS. ITS WRAPPERS AND DISPOSAL BAGS ARE ALSO COMPOSTABLE WHILE ITS OUTER PACKAGING IS OF RECYCLABLE PAPER. THEIR MANTRA IS "GOOD FOR YOU + THE EARTH", PROMOTING HYGIENIC AND DIGNIFIED WASTE DISPOSAL.

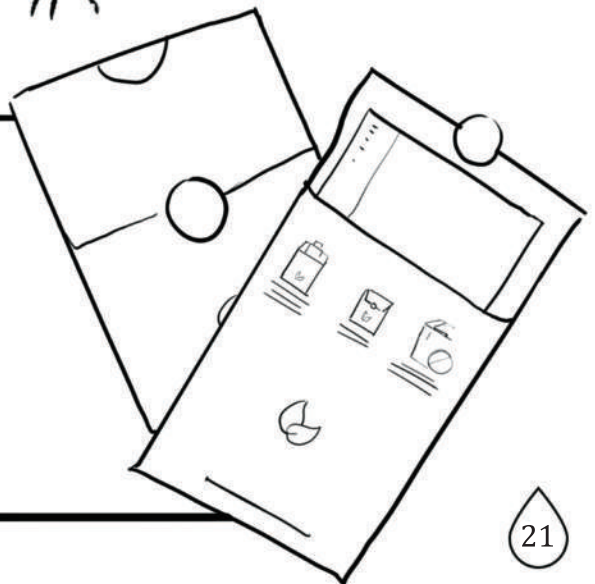

ECOFEMME 2010



WASTE WAS A CRITICAL FACTOR FOR AUROVILLE, A COMMUNITY KNOWN FOR ITS COMMITMENT TO CLEANLINESS AND SUSTAINABILITY. AIMING TO REDUCE MENSTRUAL WASTE, KATHY WALKING AND JESSAMIJN MIEDEMAJ DEVELOPED CLOTH PAD PROTOTYPES, A SUSTAINABLE OPTION. THEY COLLABORATED WITH THE AUROVILLE VILLAGE ACTION GROUP (AVAG). THE PROTOTYPES WERE TESTED BY WOMEN AND ADOLESCENT GIRLS IN RURAL DISTRICTS OF TAMIL NADU. THEY FOLLOWED THIS WITH A SURVEY TO UNDERSTAND THE MENSTRUAL MANAGEMENT NEEDS OF WOMEN.

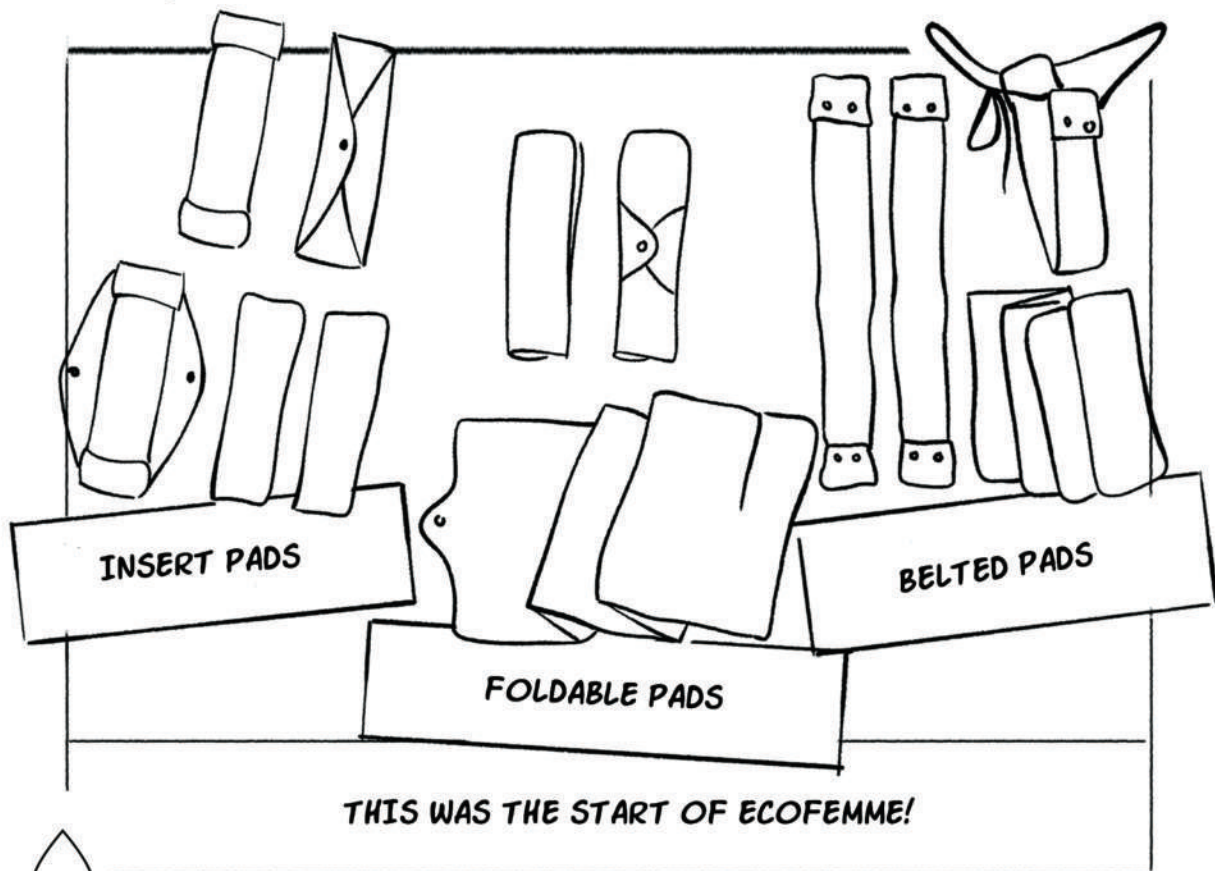

THEY TOOK FEEDBACK FROM USERS. RESULTS FROM THE SURVEY INFORMED THE DESIGN OF THE CLOTH PADS. ECOFEMME THEN DEVELOPED AND TESTED WASHABLE CLOTH PADS SPECIFICALLY FOR RURAL USERS.

AFFORDABLE

FOR MENSTRUATORS WITH LIMITED RESOURCES

QUALITY

THAT WOULD ENCOURAGE MENSTRUATORS TO PRIORITIZE ESSENTIAL CARE (CLEANSING, DRYING, AND PROPER STORAGE)

DURABLE

TO LAST A MINIMUM OF THREE YEARS

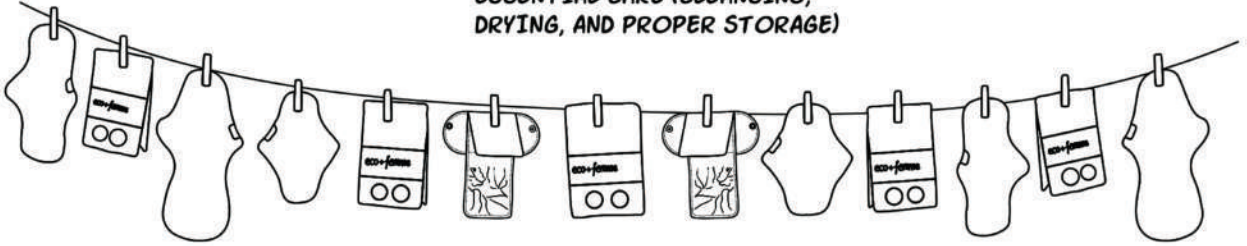

ECOFEMME SUCCESSFULLY CREATED THE FOLLOWING PRODUCTS:-

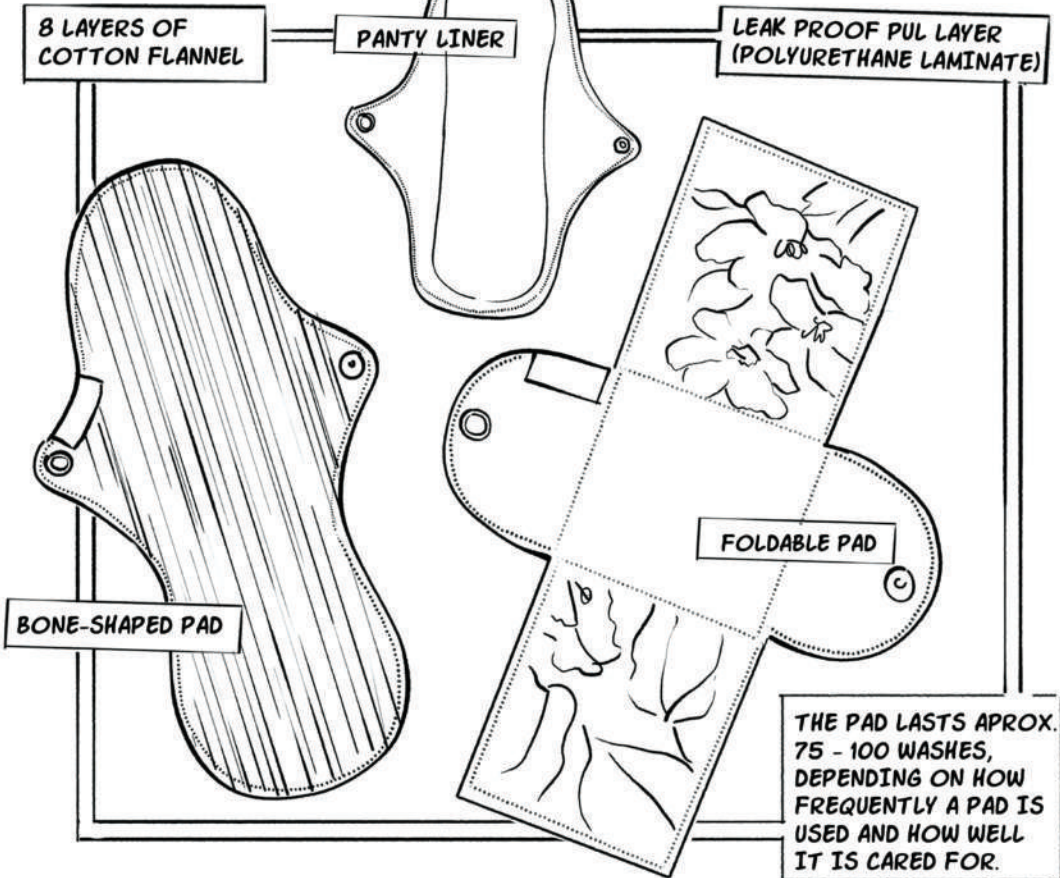

CLOTH PADS ALL OVER THE WORLD HAVE GAINED MOMENTUM SINCE !

TIME PIECE 2010

LAL KAPDA

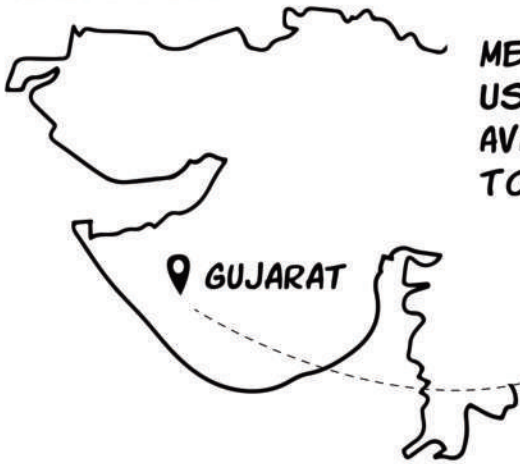

MENSTRUATORS IN SOUTH RAJASTHAN USE(D) ANOTHER TYPE OF CLOTH AVAILABLE IN THE BAZAAR REFERRED TO AS TIME PIECE OR "FALANIL".

TIME PIECE (TP) WAS ORIGINALLY A FABRIC TO WASH TRUCKS AND CARS. SOUTH RAJASTHAN VENDORS USED TO GO TO GUJARAT TO BUY WHOLESALE ITEMS SUCH AS BINDIS AND BANGLES. AND ITS THEN THEY HEARD ABOUT A "CLOTH FOR PERIODS" FROM GUJARATI SUPPLIERS. TIME PIECE ENTERED THE RAJASTHAN MARKETS AND BECAME A VERY POPULAR ITEM WITH MENSTRUATORS.

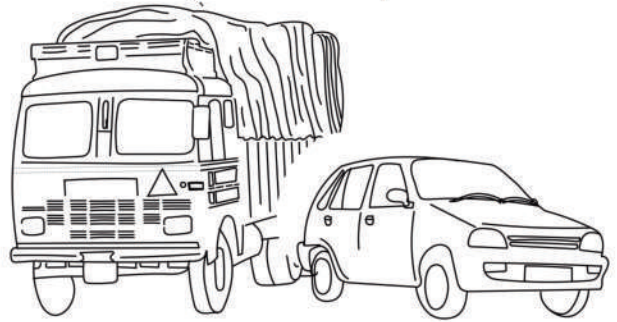

I HAVE HEARD SOME FANCY LADIES CLOTH HAS ARRIVED FROM GUJARAT CAN YOU PLEASE SHOW ME THAT?

IT WAS SOLD IN BULK - 24 PIECES IN ONE PACK TO VENDORS. CHERRY, MAROON, RED, WERE THE COLOURS THAT WERE FAVOURED. THESE WERE PIECES OF FLEECE FABRIC 10 X 12 INCHES, COSTING BETWEEN RS 10 TO RS 12. "SOME LADIES FEEL SHY WHEN THEY ASK FOR TIMEPIECE, SO THEIR HUSBANDS COME TO BUY THEM."



THERE ARE TWO TYPES OF TIME PIECES.

UNSTITCHED TIMEPIECE

COMES FROM THE TERM "CUT PIECE" MEANING PIECE OF FABRIC AND, "TIME" FOR THAT TIME OF THE MONTH. USERS WHO USE TP ALSO FOLLOW THE SAME METHOD OF FOLDING AND REFOLDING CLOTH PLACING THIS IN THEIR UNDERWEAR.

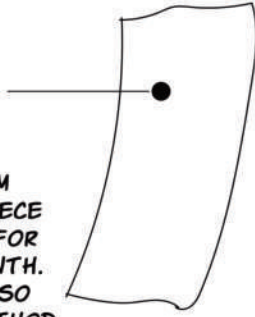

STITCHED TIMEPIECE

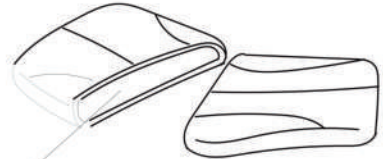

THE STITCHED VERSION WAS MADE INTO THE SHAPE OF A PAD WITH A SPONGE CORE IN BETWEEN.

FALANIL IS SO EASY TO WASH AND DRIES QUICKLY AS WELL! I ALWAYS PREFER IT DURING MY TIME OF THE MONTH.

EXACTLY! AND IT DOESN'T STAIN AT ALL! SO COMFORTABLE THAT IT ALWAYS FEELS CLEAN..

I GET SEVERE IRRITATION WHEN I USE THIS. SOME MONTHS I MANAGED THE IRRITATION WITH AN OINTMENT THAT WAS PRESCRIBED AT THE CLINIC. I GAVE UP TIME PIECE AFTER SOME TIME . I AM BACK TO CLOTH .



TIME PIECE OR LAL KAPDA - HAS MANY PROPERTIES MAKING THIS A POPULAR OPTION. IT IS AFFORDABLE AT RS 10 TO RS 20 PER PIECE AND IT CAN BE WASHED AND REUSED AGAIN AND AGAIN FOR UP TO TO 3 MONTHS. IT WASHES OFF EASILY. STAINS ARE NOT VISIBLE ON THE DARK SURFACE SO MENSTRUATORS FEEL THEY CAN HANG THE CLOTH OPENLY ON THE WASHING LINE. HOWEVER, THE FLIP SIDE IS - IT DOES NOT SUIT MANY USERS.

UGER, JATAN SANSTHAN

2010

THE LACEWALAH KAPDA WAS DEVELOPED BY VIKALPDESIGN IN 2000. HOWEVER, BY 2010, LAKSHMI MURTHY FOUND THAT IT LOST ITS POPULARITY.



MADAMJI. MANY OF US WEAR UNDERWEAR. NOW, WE SIMPLY PLACE CLOTH IN OUR UNDERWEAR DURING THIS TIME.

LAKSHMI REVISITED HER EARLIER PAD DESIGN. COLLABORATING WITH JATAN SANSTHAN, UDAIPUR

SHE AND THE JATAN TEAM MEMBERS THEN BEGAN AN INTENSIVE DESIGN EXERCISE - TO DEVELOP A REUSABLE PAD THAT COULD BE FIXED TO THE UNDERWEAR.



LAKSHMI MURTHY AND KAILASH BRIJUWASI, COFOUNDERS OF JATAN, STARTED AFRESH. THEY BEGAN THE CHUPPI TODO ABHIYAAN (BREAK THE SILENCE CAMPAIGN).

AFTER A LOT OF PROTOTYPES.....

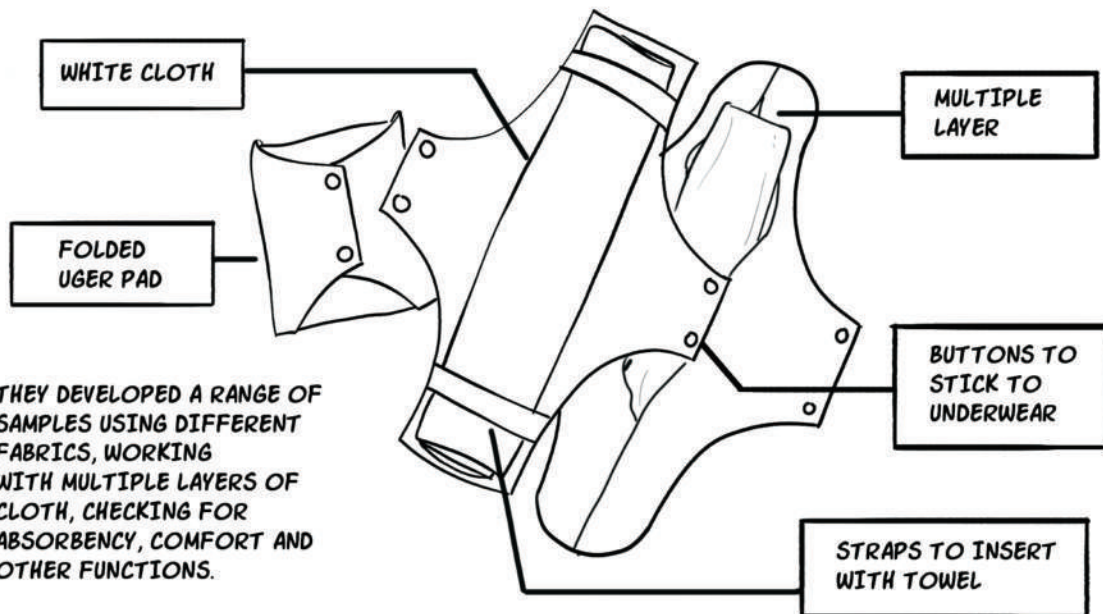

THEY DEVELOPED A RANGE OF SAMPLES USING DIFFERENT FABRICS, WORKING WITH MULTIPLE LAYERS OF CLOTH, CHECKING FOR ABSORBENCY, COMFORT AND OTHER FUNCTIONS.

SAMPLES ARE READY TO USE, BUT UNLESS WE TEST IT ON OURSELVES, HOW WILL WE KNOW IF IT'S WORKING? SO LET'S ALL USE THE PADS!





OVERALL THE DESIGN TEAM MEMBERS WERE SATISFIED WITH THE PERFORMANCE OF THE PADS. AFTER THIS QUICK TEST, A SET OF 100 PADS WERE MADE AND DISTRIBUTED AMONG FAMILY AND FRIENDS AND THE JATAN OFFICE TEAM. THERE WERE DIVERSE VIEWS ABOUT THE PADS!



6 PADS NEEDED FOR 1 MENSTRUAL CYCLE



I USED THE PAD THREE TIMES ... THERE IS TOO MUCH WASHING AND MAINTENANCE, I CANNOT CARRY ON WITH THIS, I AM HAPPY WITH DISPOSABLE PADS.

I ALWAYS GET RASHES FROM DISPOSABLE PADS, THEIR CLOTH PADS GAVE ME NO PROBLEM, I HAVE TRIED THESE NOW FOR THE PAST 4 MONTHS.



I AM GOING TO USE A COMBINATION - CLOTH PAD WHEN I AM AT HOME AND DISPOSABLE WHEN I GO OUTSIDE.

I AM HAPPY THAT THERE IS A MENSTRUAL PRODUCT CAUSING NO DAMAGE TO THE ENVIRONMENT.



EXCITED BY THE INITIAL RESPONSE, THE CLOTH PAD WAS GIVEN A NAME - UGER. UGER MEANS "NEW BEGINNINGS" IN THE MEWARI LANGUAGE OF SOUTH RAJASTHAN. THE WAY FORWARD WAS A PILOT TRIAL WITH 38 WOMEN, WHO USED WORE PADS OVER THEIR 4 MENSTRUAL CYCLES.

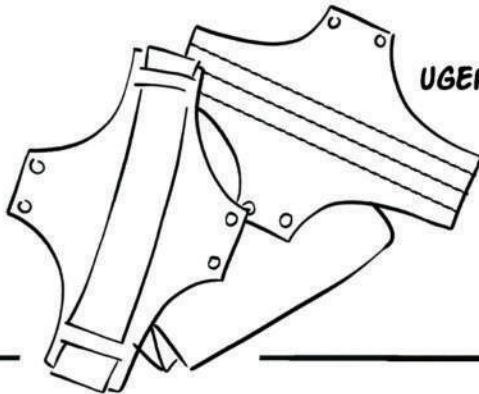
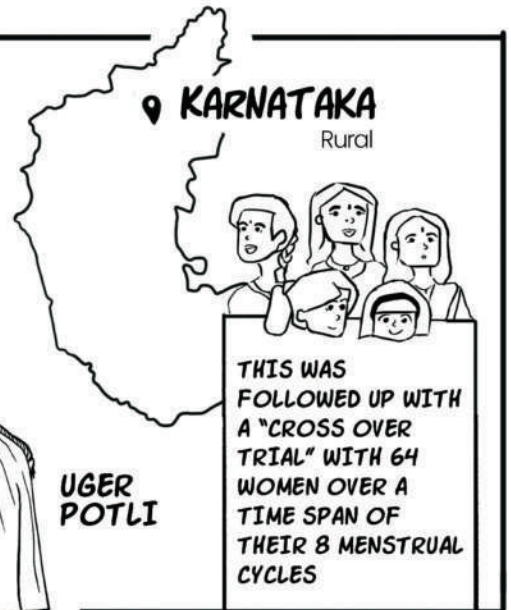

UGER PADS



UGER POTLI

JATAN SANSTHAN TOOK FORWARD UGER PADS IN 2 WAYS - STARTING A SMALL PAD PRODUCTION UNIT - INVITING 8 TO 10 WOMEN. A "WORK FROM HOME" MODEL WAS USED WHERE WOMEN TOOK HOME PRE CUT FABRICS AND STITCHED THE PADS AT HOME. SIMULTANEOUSLY, MENSTRUATORS WERE TAUGHT UGER PAD STITCHING - MENSTRUATORS BEGAN TO HAND STITCH THEIR OWN UGER PADS. UGER PADS WERE THEN PUT IN THE COPY LEFT SPACE* FOR ANYONE TO USE OR MODIFY! JATAN SANSTHAN ALSO DEVELOPED A VARIETY OF COMMUNICATION PRODUCTS FOR MENSTRUAL HEALTH TRAINING PROGRAMMES.



* THE ORIGINAL CREATOR GRANTS THE FREEDOM TO USE, COPY, MODIFY, AND REDISTRIBUTE THE WORK



DISPOSABLE PADS



LABIAL PADS

<https://www.sochgreen.com>



CUPS

<https://shecup.com>

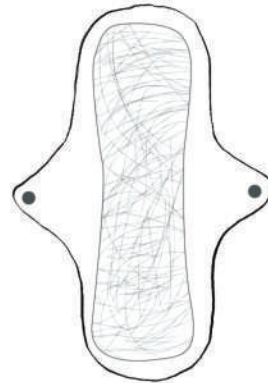

CLOTH PADS

(banana/bamboo fibre core)

<https://saathipads.com>
<https://saukhyampads.org>

This decade saw the rise of reusable products. Menstrual cups were now available. Cups caught the imagination of menstruators for its ease of maintenance and environmental benefits.

More reusable cloth pads were available for users, including labial pads. Many of these products were available online.

2020

SHECUP 2010



THE MALANI BROTHERS ASHISH AND MANISH LOST A CLOSE FAMILY MEMBER TO CERVICAL CANCER. IT WAS THEN THEY REALISED HOW DIFFICULT IT IS FOR WOMEN TO VOICE THEIR PAIN AROUND MENSTRUATION.

THE BROTHERS AIMED TO START CONVERSATIONS AROUND MENSTRUATION, ITS MANAGEMENT AND ADDRESS TABOOS. WHILST DOING SO, THEY ASKED THEMSELVES -



HOW CAN WE TAKE THIS A STEP FURTHER THAN JUST TALKING ABOUT IT?

WHAT MORE CAN WE DO?

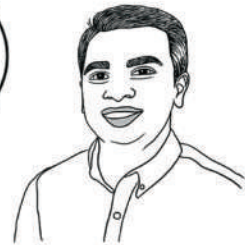

THIS LEAD THEM TO START CONVERSATIONS AROUND SUSTAINABLE MENSTRUATION.

SHECUP WAS ONE OF THE FIRST BRANDS TO GIVE USERS A PLATFORM TO CONNECT DIRECTLY WITH THE COMPANY FOR QUERIES AND OTHER INFORMATION.

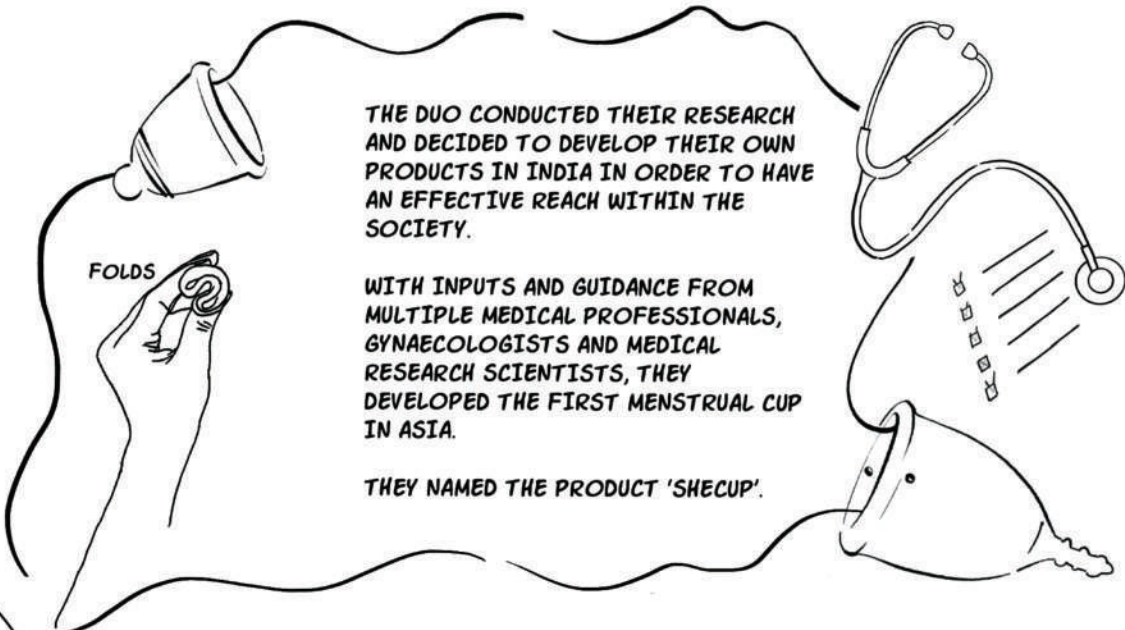

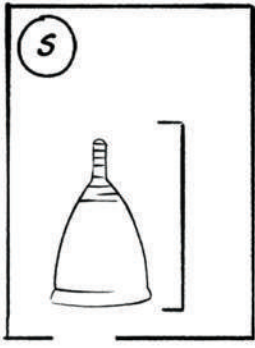

ADD TO CART

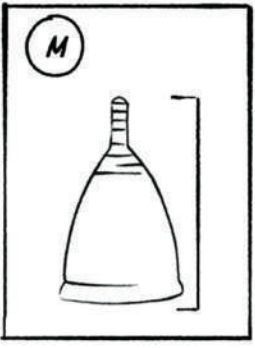

ADD TO CART

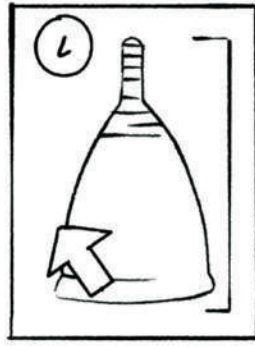

ADD TO CART

**SIZING??
WHAT??**



DURING THE COURSE OF EXPERIMENTS AND TRIALS, THEY UNDERSTOOD THE MANY APPREHENSIONS OF CONSUMERS. SIZE OF THE CUP APPEARED TO BE A PRIMARY CONCERN WITH USERS.

MENSTRUAL DISCHARGE VARIES FOR MENSTRUATORS, THEREFORE, THEY SELECT PRODUCTS ACCORDINGLY. A ONE-SIZE-FITS ALL MENSTRUAL CUP WAS DEVELOPED IN CONSULTATION WITH MEDICAL EXPERTS.



THE SHECUP IS AN FDA (FOOD AND DRUG ADMINISTRATION) COMPLIANT, HEALTH GRADE, NON-TOXIC AND NON-ALLERGIC CUP.

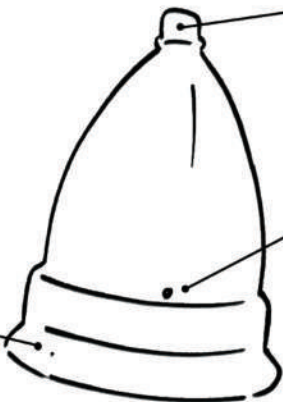

KNOB FOR GOOD GRIP WHILE PLACING OR TAKING OUT

AIR HOLES - TO RELEASE SUCTION

OUTER RIM

SAATHI PADS 2015

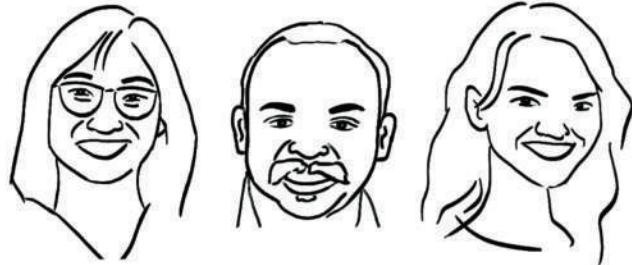

SAATHI BEGAN IN 2015. THE CO-FOUNDERS KRISTIN KAGETSU, TARUN BOTHRA, AND GRACE KANE - GRADUATES OF MIT (USA) AND NIRMA UNIVERSITY, CAME TOGETHER ON A MISSION TO CREATE FULLY ECO-FRIENDLY, COMPOSTABLE SANITARY NAPKINS USING LOCALLY SOURCED BANANA FIBER FROM GUJARAT. THEY WERE INSPIRED BY THE IDEA OF IMPROVING WOMEN'S ACCESS TO SANITARY PADS. THEY WERE PASSIONATE ABOUT MAKING A SUSTAINABLE PRODUCT USING NATURAL MATERIALS.



SAATHI'S ORIGINAL MODEL WAS MAKING AND SUPPLYING LOW-COST DISPOSABLE SANITARY PADS TO RURAL WOMEN. BUT THAT SOON CHANGED.



WHY?
"JUST DEVELOPING A LOW-COST SANITARY PAD WASN'T ENOUGH. THE ENTIRE LIFE CYCLE OF THE PRODUCT NEEDED TO BE CONSIDERED."

WHILE THE LOW COST SANITARY PAD TACKLED THE ISSUE OF ACCESS, THE ENVIRONMENTAL BURDEN REMAINED A QUESTION MARK.
DISPOSABLE PRODUCTS (NON-BIODEGRADABLE) BURDEN ANY ENVIRONMENT.

THEY SHIFTED THEIR FOCUS TO USING DIFFERENT RAW MATERIALS. SAATHI COMPOSTABLE DISPOSABLE SANITARY PADS WERE THEN MADE FROM WASTE FIBRE OF THE BANANA PLANT. THEY SOURCED RAW MATERIALS FROM A BANANA PLANTATION BELT CLOSE TO AHMEDABAD.



"A LONGER ROUTE BUT A MORE SUSTAINABLE ONE."



SAATHI PADS ARE SOLD IN BOTH URBAN AND RURAL AREAS IN INDIA

BANANA FIBRE PADS

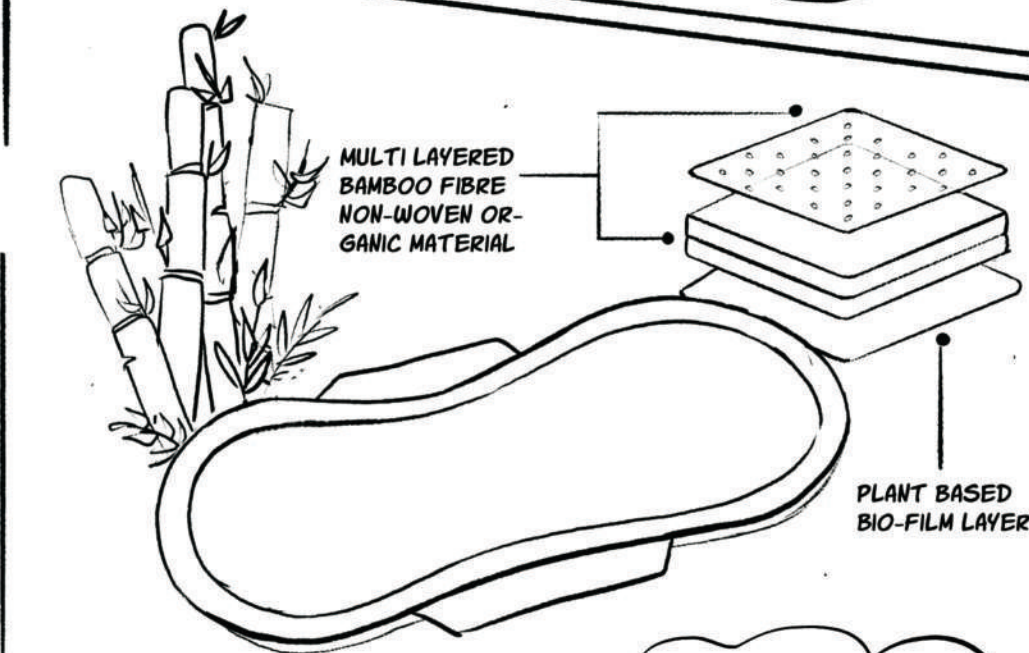
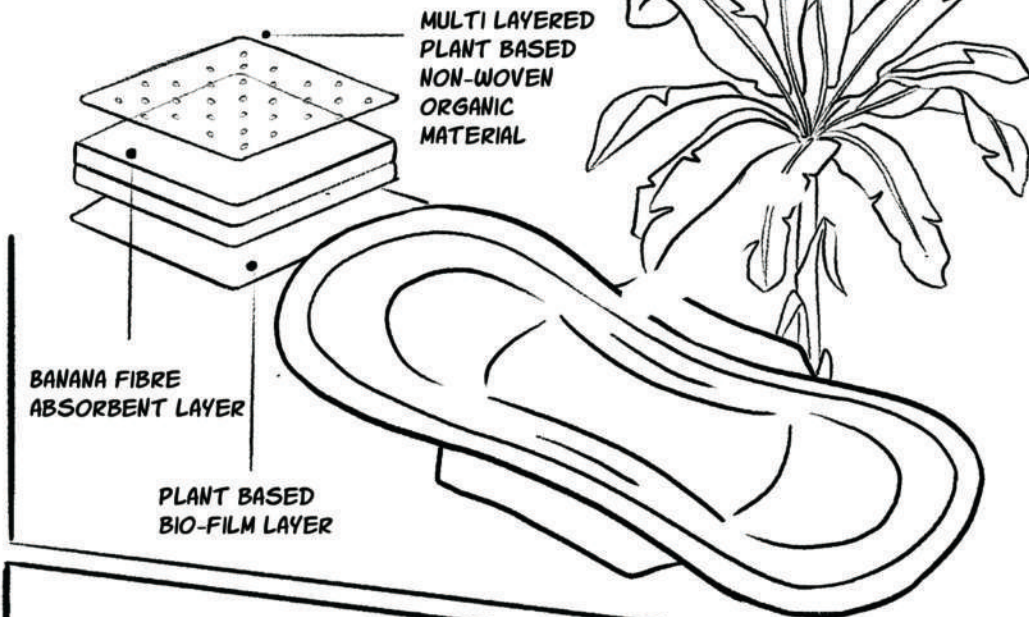

BAMBOO FIBRE PADS

NOTE: THIS SPREAD IS BASED ON PUBLICLY AVAILABLE INFORMATION AND IS YET TO BE VETTED BY THE ORGANISATION'S FOUNDERS



"SAATHI'S DREAM WAS TO PROVIDE AFFORDABLE, ACCESSIBLE AND ECO-FRIENDLY SANITARY PADS TO WOMEN ALL OVER RURAL INDIA."

BOONDH CUPS 2016



IN 2016, BHARTI KANNAN FOUNDED BOONDH TO BRIDGE THE ISSUES RELATED TO MENSTRUATION, ACTIVISM, AND ADVOCACY. SONAL JAIN JOINED IN 2017 AS A CO-FOUNDER. THEY SOUGHT TO MAKE SUSTAINABLE PERIOD PRODUCTS ACCESSIBLE AND EASY TO USE.



BOONDH WAS CONCERNED WITH EMPOWERING THE USER, HENCE WAS CONCEIVED WITH THE INTENTION TO MAKE SUSTAINABLE MENSTRUAL PRODUCTS EASY TO USE AND BUY.

THE AIM WAS TO BRING SUSTAINABLE PRODUCTS THAT SUPPORT BODY AUTONOMY, HEALTH, SOCIETY, ENVIRONMENT, CONSCIOUSNESS, AND DECISION-MAKING.

A STANDARD CUP SIZE WAS DESIGNED BASED ON REVERSE ENGINEERING ON EXISTENT AND AVAILABLE CUPS. THESE WERE DESIGNED FOR WIDE MARKET REACH.

BOONDH CUP

STANDARD (MEDIUM SIZE) CUP THAT FITS AND WORKS FOR ALL.

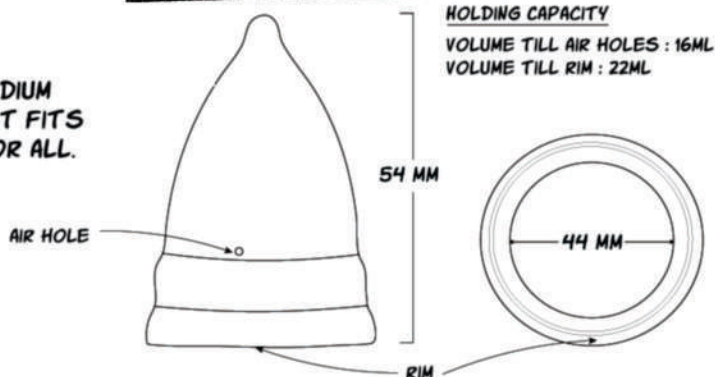

BOONDH CUP KIT



BOONDH PADS

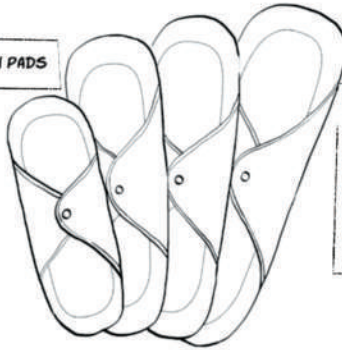

BOONDH ALSO DEVELOPED CLOTH PADS, ALONG WITH CUPS

BOONDH FOCUSED ON FOUR CORE PILLARS: SUSTAINABLE PRODUCTS, MENSTRUAL LITERACY, ADVOCACY, AND PROGRAMMING. THEY USED THEIR PLATFORM TO BREAK THE STIGMA AND ENSURE INFORMED CHOICES.

CUPS WERE RELATIVELY A NEW PRODUCT IN THE INDIAN MARKET. THE BOONDH TEAM SET UP A NON-JUDGEMENT, HANDS ON HELPLINE TO HELP USERS USE THE CUP AND TROUBLESHOOT WEARING AND REMOVING THE CUP - WITH THE CONSULTATION OF EXPERIENCED CUP USERS.



I'M WORRIED ABOUT WEARING THE CUP CORRECTLY, CAN SOMEONE HELP ME WITH GUIDANCE PLEASE ?



ABSOLUTELY, WE ARE HERE TO GUIDE NEW USERS, YOU CAN EVEN CONSULT EXPERIENCED CUP USERS.

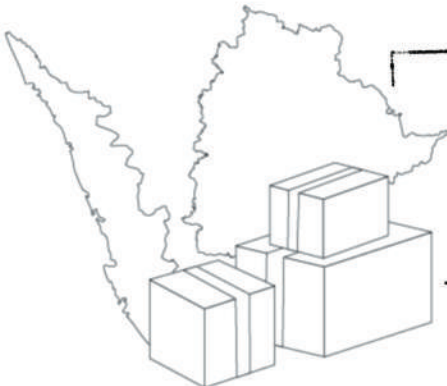

THE ADVOCACY AND CAMPAIGNING WORK WITH SUSTAINABLE PRODUCTS HAS DIRECTLY INFLUENCED POLICY, BOONDH LED CAMPAIGNS RESULTED IN LOCAL SELF-GOVERNMENTS IN KERALA AND TELANGANA ESTABLISHING THEIR OWN 'GREEN PERIOD ADMINISTRATIVE UNITS'

KERALA



IN 2013, SRI MATA AMRITANANDAMAYI DEVI, THE FOUNDER OF MATA AMRITANANDAMAYI MATH, PARTNERED WITH 100 VILLAGES ACROSS INDIA TO SUSTAINABLY DEVELOP THEM. UPON NOTICING THE ISSUES OF ACCESS TO CLEAN MENSTRUAL PRODUCTS, AMMA AND HER TEAM LED ON A JOURNEY OF CREATING EFFECTIVE CLOTH PADS USING BANANA FIBRE. BANANA FIBRE IS A TYPE OF CELLULOSE THAT CAN ABSORB LIQUIDS AND THUS, A GOOD MATERIAL TO USE IN THE PADS.

AMMA NOT ONLY WANTED TO PROVIDE A SAFE-TO-USE, GOOD-QUALITY PAD BUT ALSO MADE SURE IT DIDN'T HARM THE ENVIRONMENT. SHE ALSO WANTED TO HELP PROVIDE LIVELIHOODS TO THOUSANDS OF RURAL WOMEN THROUGH THE PRODUCTION OF THESE CLOTH PADS.



DRIVEN BY A MOTIVATION TO REDUCE EMISSIONS, CARBONFOOTPRINT AND PROMOTE SUSTAINABLE LIVING,

SAUKHYAM ALSO CREATED REUSABLE MENSTRUAL PAD FROM BANANA FIBER

BANANA FIBRE DERIVED FROM AGRO-WASTE IS USED TO ADVANTAGE. AT THE SAME TIME BENEFITING LOCAL FARMERS.

BANANA TREE AGRO-WASTE

BANANA FIBRE

SAUKHYAM'S DESIGN TEAM USED THIS CELLULOSE FIBRE ABSORBING SIX TIMES ITS DRY WEIGHT. THE BANANA PLANT IS USUALLY CUT DOWN RIGHT AFTER BEARING FRUIT, AND IN KERALA, THERE IS NO DEARTH OF THIS RAW MATERIAL. EXPERIMENTS WITH THIS FIBRE BEGAN, THE PADS WERE SOON DEVELOPED. WHILE IT WAS INITIALLY STARTED IN KERALA, THE INITIATIVE SLOWLY GREW IN MULTIPLE STATES ACROSS INDIA.

SIDE 1

SIDE 2

INSERT PAD

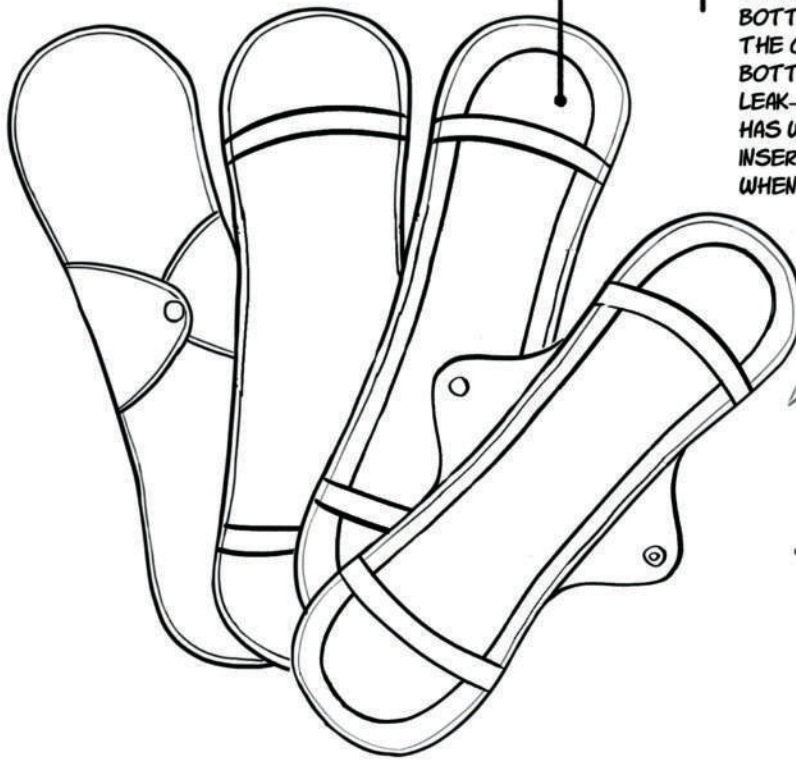

THE DESIGN FEATURES: TOP AND BOTTOM LAYERS ARE COTTON FABRIC, THE CORE IS OF BANANA FIBRE, THE BOTTOM LAYER IS A POLYURETHANE LEAK-PROOF LAYER. THE PAD HOLDER HAS WINGS WITH STRAPS FOR PLACING INSERTS WHICH ARE NEEDED DURING DAYS WHEN THERE IS GREATER FLOW.



WITH A PRODUCTION AND DISTRIBUTION SYSTEM SPANNING MULTIPLE STATES, THEIR MAIN FACTORY IS IN KERALA.

SEMI-STITCHED TEMPLATES ARE DISPATCHED TO RURAL SATELLITE PRODUCTION CENTRES LOCATED ACROSS THE COUNTRY. WOMEN HAVE BEEN TRAINED TO COMPLETE THE SEMI-STITCHED PADS. THE FINISHED PRODUCTS ARE THEN READY FOR DISTRIBUTION.



THE SOUKHYAM PAD CAN BE WASHED AND REUSED JUST AS ANY REUSABLE PAD FOR UPTO TO THREE YEARS.

SOCHGREEN 2017

NEW DELHI

RECOGNIZING THE HEALTH AND FINANCIAL BENEFITS OF MENSTRUAL CUPS, FOUNDERS PRIYANKA JAIN AND PRANAV JAIN BEGAN PROMOTING AND SELLING VARIOUS TYPES OF MENSTRUAL CUPS.

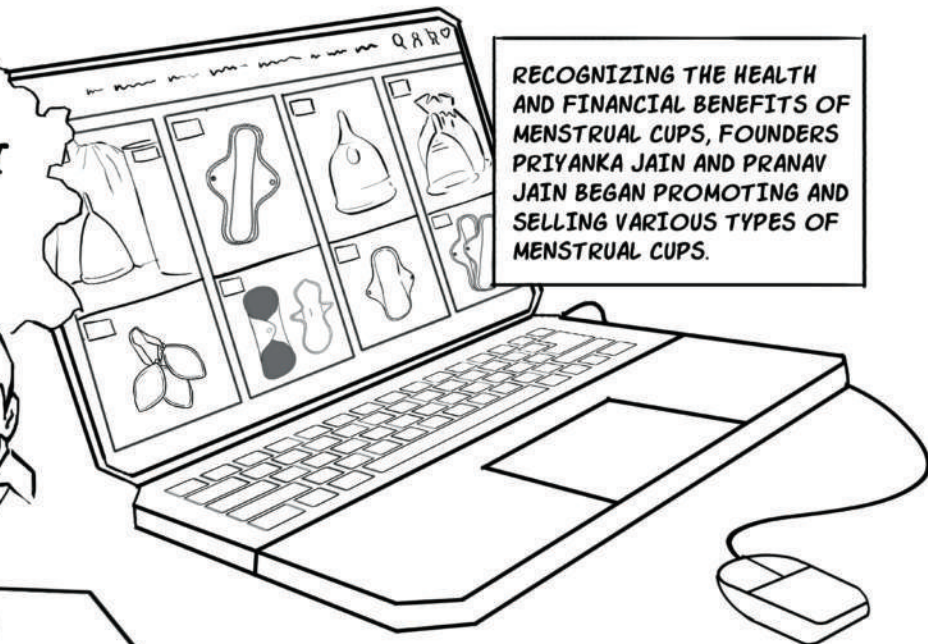

WANTING TO OFFER SUSTAINABLE AND HEALTH-FRIENDLY ALTERNATIVES TO WOMEN WHO WERE NOT COMFORTABLE USING CUPS- WE ALSO STARTED SELLING CLOTH PADS FROM DIFFERENT BRANDS. A RANGE OF PRODUCTS WAS MADE AVAILABLE ON OUR WEBSITE.

RECOGNIZING THE NEED FOR HIGHLY ABSORBENT CLOTH PADS, WE AIMED TO DEVELOP PADS WITH BETTER ABSORBENCY. MANY CUSTOMERS PREFERRED 100% COTTON PADS. HOWEVER, THERE WERE OTHERS WHO SHARED THAT CLOTH PADS MADE FROM A BLEND OF COTTON-POLYESTER RETAINED QUALITY THROUGH MULTIPLE USES AND IN ADDITION DRIED FASTER.

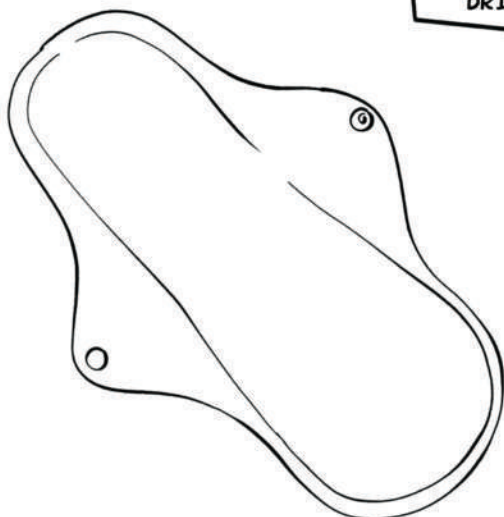

SOCHGREEN THEN LAUNCHED TWO TYPES OF PADS TO CATER TO BOTH SETS OF USERS-

1. TOP LAYER: 100% COTTON
• ABSORBENT CORE: MICROFLEECE
• BOTTOM LAYER (LEAKPROOF): PUL
2. TOP LAYER: 50% COTTON AND 50% POLYESTER
• ABSORBENT CORE: MICROFLEECE
• BOTTOM LAYER LEAKPROOF LAYER: PUL

PUL = POLYURETHENE LAMINATE

WHILE THE FOUNDERS WERE ABLE TO INCREASE THE ABSORBENCY OF THE CLOTH PADS TO SOME EXTENT, THEY REALIZED THAT CLOTH PADS WERE NOT SUFFICIENT FOR CONDITIONS LIKE ENDOMETRIOSIS AND POSTPARTUM BLEEDING.

THIS LED THEM TO DISCOVER LABIAL PADS, WHICH WERE ONLY AVAILABLE IN SOME COUNTRIES. THEY MADE SAMPLES OF LABIAL PADS AND TESTED THEM.

CENTRAL EXTRA PROTECTION

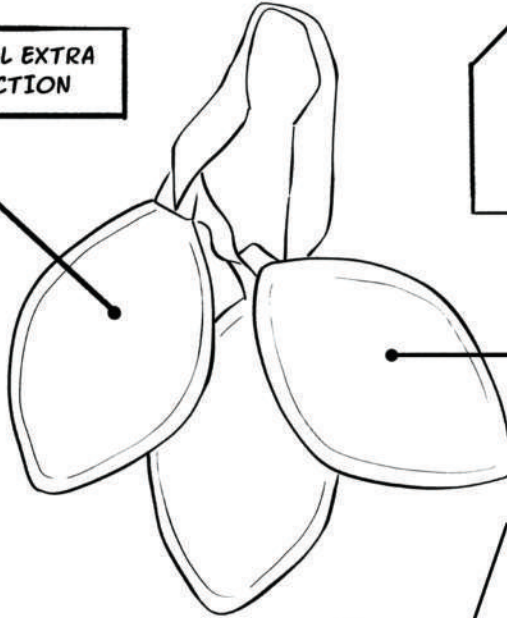

THE PAD IS SHAPED LIKE A LEAF AND IS WORN IN COMBINATION WITH OTHER ABSORBENTS. IT IS PLACED WITHIN THE FOLDS OF THE LABIA (THIS IS NOT INSERTED LIKE IN A CUP).

LEAF-SHAPED DESIGN WHICH DIRECTS BLOOD FLOW TOWARDS THE END OF THE PAD.

THE LABIAL PAD CATCHES AND DIRECTS/DIVERTS A SUDDEN HEAVY FLOW (OR A FLOW WITH CLOTS) ON TO A CLOTH OR PAD, PERIOD PANTY

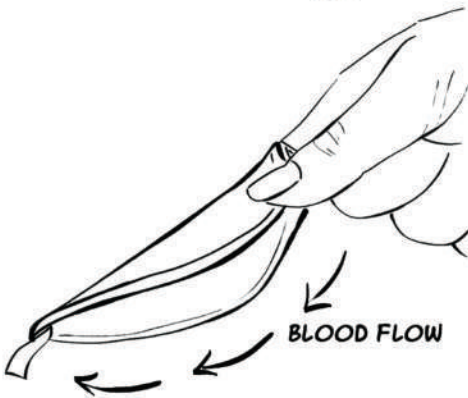

I HAVE ENDOMETRIOSIS. I REQUIRE HOURLY CLOTH PAD CHANGES. I FOUND THIS TO BE IDEAL. I ABSOLUTELY LOVE IT!



THE SOCH GREEN LABIAL PADS ARE AVAILABLE IN TWO SIZES- SMALL AND LARGE AND ARE SOLD IN SETS OF THREE.

LABIAL PADS TURNED OUT TO BE GAME CHANGERS

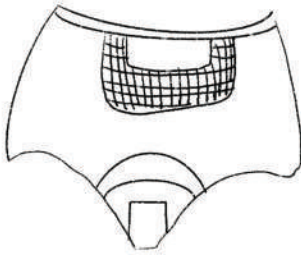

**MIMA 2.0 - MULTIFUNCTIONAL
SMART WEARABLES IOT
INTEGRATED MENSTRUAL AID**



- PADS WITH DIFFERENT VARIATIONS:**
- GEL CONVERTING PAD
 - PAD WITH REMOVABLE DRIED BLOOD COLLECTION STRIP
 - PAD EMBEDDED WITH BIOSENSORS
 - PAD WITH COATING TO REDUCE CRAMPS
 - PAD WITH PHOTOCATALYST
 - COMPOSTABLE PAD WITH BIOCOAGULANT

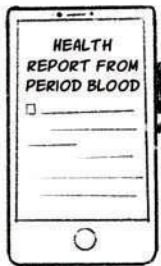

**USING MENSTRUAL BLOOD
FOR DIAGNOSTICS**

Menstrual health and hygiene products have entered a new era - from smart fabrics to diagnostic pads, technology and innovation are reshaping how we experience, understand, and manage menstruation.

Across the world and in India, consumers are seeking choice, comfort, safety, dignity, and sustainability - driving a wave of R&D that extends beyond absorbent products to products that collect menstrual discharge, disposal and end-of-life treatment of used products, tracking and diagnostics in a deeply interconnected and rapidly evolving global marketplace.

Importantly, the narrative is shifting - menstrual blood is no longer hidden or dismissed as waste, but is being valued as a powerful data source unlocking health insights.

PRESENT

INNOVATION IN MENSTRUAL PRODUCTS

PADS THAT TEST, NOT JUST ABSORB - PERIOD BLOOD AS A DIAGNOSTIC FLUID

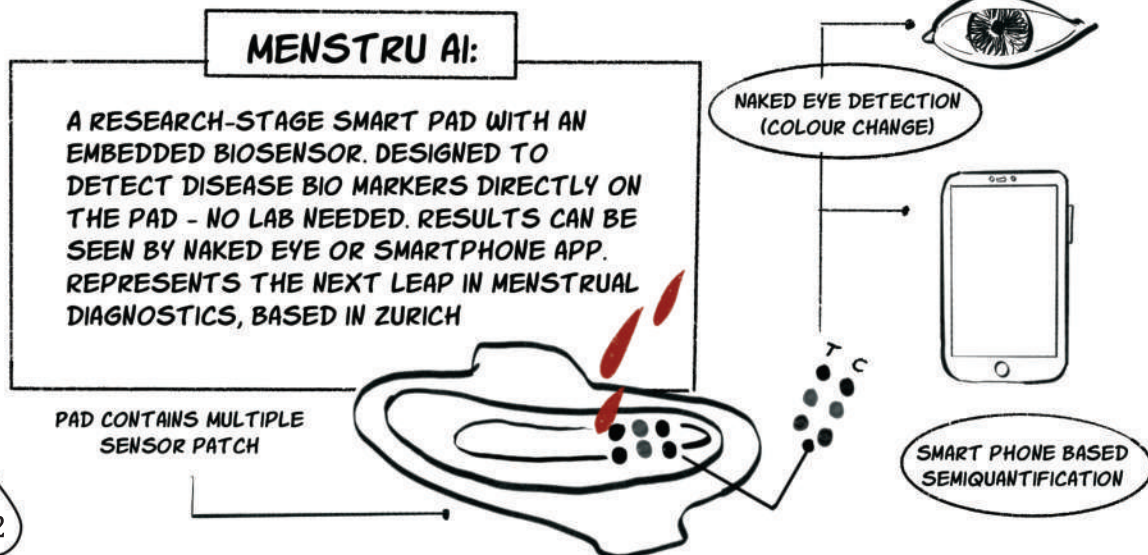
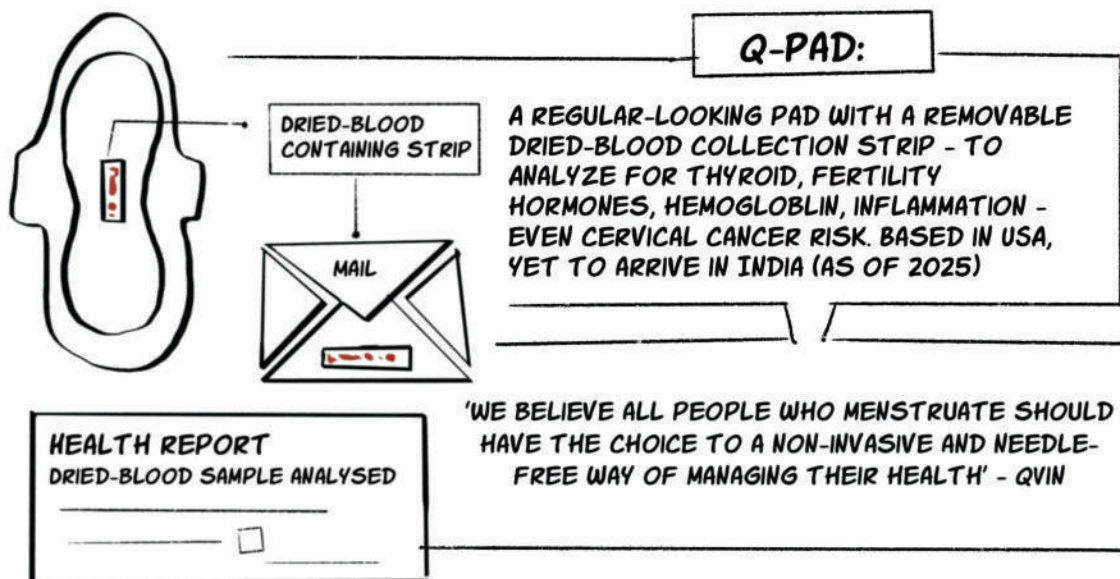

SMART WEARABLES FOR COMFORT

MIMA 2.0 (MULTIFUNCTIONAL SMART WEARABLES IOT INTEGRATED MENSTRUAL AID)

IOT-ENABLED INTIMATE WEAR WITH BLUETOOTH-CONTROLLED HEATING, CLAIMS TO HAVE LEAKPROOF AND ANTIBACTERIAL LINING. IT WILL ADDRESS CRAMPS, ODOUR, AND RASH IN A UNIFIED DESIGN BASED ON RESEARCH CONDUCTED IN NISER (NATIONAL INSTITUTE OF SCIENCE EDUCATION AND RESEARCH), INDIA.

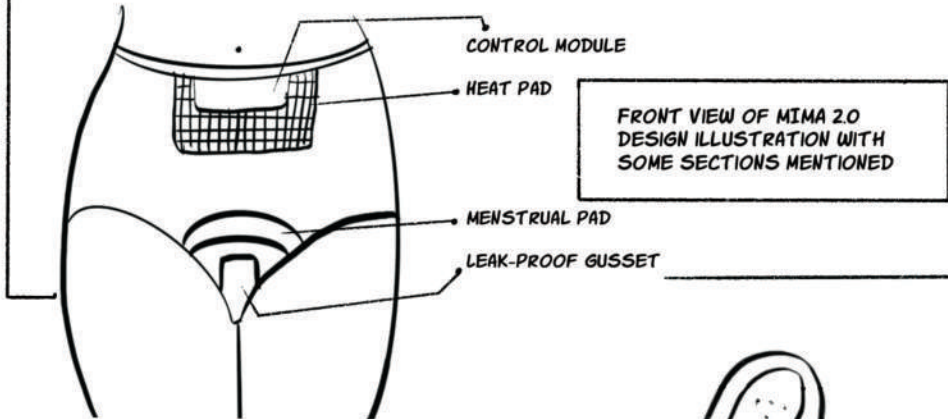

GEL CONVERTING PAD

NEW BIOMATERIAL PAD THAT TURNS BLOOD INTO GEL, CLAIMING TO REDUCE MESS AND BACTERIA, PREVENTING LEAKAGE BASED ON RESEARCH CONDUCTED IN VIRGINIA TECH.

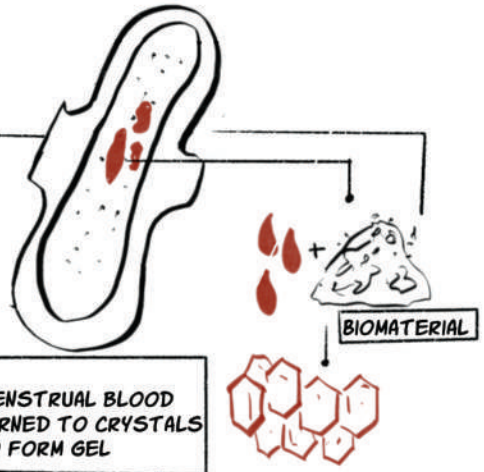

TULIPON

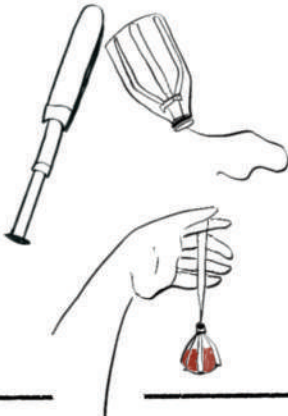

A HYBRID MENSTRUAL DEVICE COMBINING TAMPON USABILITY WITH MENSTRUAL CUP CAPACITY (UP TO ~12 HOURS OR ~45ML FULL) AND BUILT-IN BIOMETRIC MONITORING FOR WELLNESS INSIGHTS, INCLUDES AN AI-POWERED APP AND WATER-DISSOLVING APPLICATOR. THE PRODUCT IS IN EARLY ACCESS/PRE-MARKET PHASE, NOT YET BROADLY COMMERCIALISED, BASED IN ISRAEL.

INNOVATION IN MENSTRUAL PRODUCTS

MAGNA PADS

THESE PADS ARE COATED WITH MAGNESIUM HYDROGEN, WHICH THE COMPANY CLAIMS MAY REDUCE MENSTRUAL CRAMPS. THEIR FUTURE CONCEPT INCLUDES ADDING A DIAGNOSTIC CHIP - DESIGNED TO DETECT CONDITIONS LIKE PCOD AND CERTAIN CANCERS. THIS PRODUCT IS CURRENTLY IN TRIAL PHASE AT 25 RUPEES EACH, DEVELOPED BY A PHARMACY STUDENT FROM VIJAYAWADA, INDIA.

MAGNA PAD CONTAINS EIGHT LAYERS



COATED WITH MAGNESIUM HYDROGEN

SUN PAD

A WASHABLE COTTON PAD WITH A MINERAL-BASED COATING CALLED PHOTOCATALYST THAT THE COMPANY CLAIMS BECOMES 'SELF-SANITISING' WHEN DRIED IN THE SUN - KILLING OVER 99.9% OF MICROBES WHILE REMOVING ODOURS AND STAINS. BEING DEVELOPED BY CARDIFF UNIVERSITY WITH PARTNERS IN NEPAL.

PHOTOCATALYST ~ SELF-SANITISING

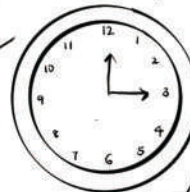
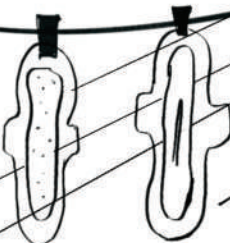

15 MINUTES

FLUSHABLE PADS

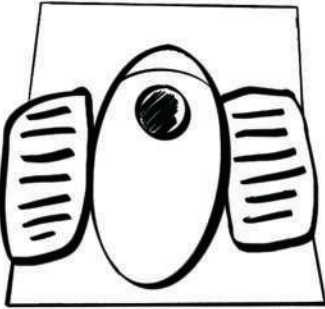

FLUUS

FLUSHABLE, BIODEGRADABLE PADS
(MICROPLASTIC FREE) - BASED IN UK



CRESA

CLAIMS TO DISSOLVE IN HOT
WATER WHICH CAN THEN BE
FLUSHED. BASED IN INDIA.

ANABIO

FLUSHABLE PADS ARE CLAIMED TO
DISSOLVE DIRECTLY IN THE WATER UPON
FLUSHING WITH STRONG WATER FLOW.
THIS IS MADE FROM PLANT-BASED,
BIODEGRADABLE MATERIALS. CURRENTLY
AVAILABLE TO BUY (4 FOR 100 RUPEES) ON
THEIR WEBSITE (WITH MASS RETAIL
PENDING). BASED IN INDIA



HOWEVER, WHERE SEWAGE SYSTEMS ARE UNEVEN AND
SANITATION LABOUR REMAINS STRATIFIED BY CASTE, THE IDEA
OF 'FLUSHABLE' MENSTRUAL PRODUCTS DEMANDS CAUTION -
WHAT DISAPPEARS FROM SIGHT MAY STILL BURDEN THOSE
WHO CLEAN AND MAINTAIN WHAT LIES BENEATH.

PAPAYA PAD

COMPOSTABLE, PLASTIC-FREE MENSTRUAL
PADS MADE FROM COTTON AND CELLULOSE,
USING A NATURAL BIOCOAGULANT THAT
SOLIDIFIES MENSTRUAL FLOW. THE COMPANY
REPORTS THAT PADS WERE TESTED USING
REAL BLOOD, INSTEAD OF THE BLUE SALINE
NORM. THE INDIAN-BASED START-UP CLAIMS IT'S
PADS CAN DECOMPOSE EVEN IN LANDFILLS,
CITING A SOIL BURIAL TEST WHERE THE
PRODUCT DISINTEGRATED WITHIN 120 DAYS AND
FULLY BROKE DOWN IN ABOUT EIGHT MONTHS.

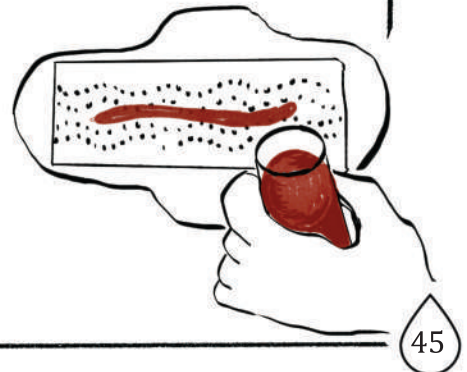

INNOVATION IN MENSTRUAL PRODUCTS

RECYCLING USED PADS

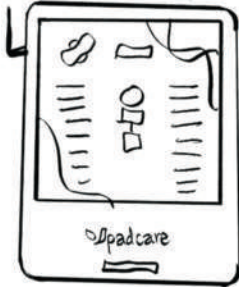

PADCARE LABS:
TURNS USED PADS INTO PULP AND PLASTIC, CLOSING THE LOOP FROM WASTE TO RESOURCE.

THROUGH ITS PADCARE X UNIT, BIN LINERS WITH USED PADS GO THROUGH A 5D PROCESS

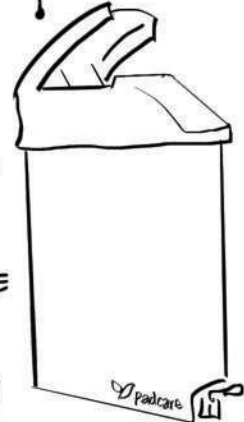
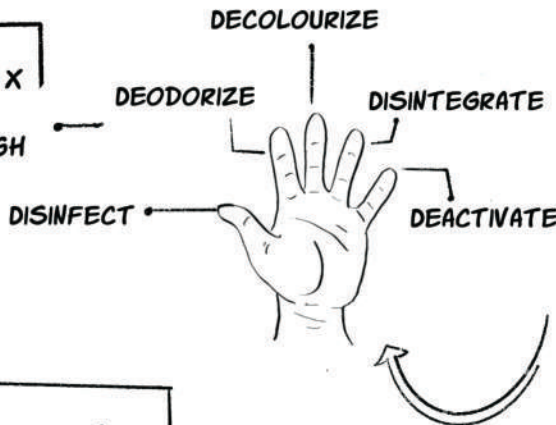

A GREEN CYTOSLAY FORMULA THAT NEUTRALISES THE ABSORBENT GEL AND SANITISES EVERYTHING. IN MINUTES, 100% PULP AND PLASTIC ARE RECOVERED FOR REUSE IN PACKING, TEXTILES, AND CHEMICALS.



DISCLAIMER:
THESE INNOVATIONS ARE EXCITING BUT STILL IN EARLY OR PILOT STAGES. ONLY A FEW ARE MARKET-READY, AND THEIR LONG TERM VIABILITY AND SUITABILITY FOR DIVERSE INDIAN CONTEXTS ARE YET TO BE ESTABLISHED.

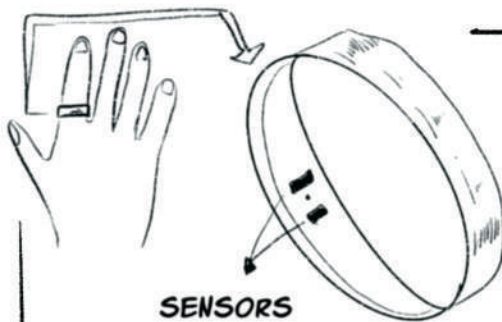

OURA RING

AI-DRIVEN TRACKING DEVICES:

SMART WEARABLES DETECT SUBTLE BODY CHANGES TO PREDICT OVULATION AND CYCLE SHIFTS WITH NEAR-CLINICAL PRECISION, OURA RING US BASED IN FINLAND.

AI CHATBOTS AS COMPANIONS:

FREE, FRIENDLY, VOICE-BASED TOOLS THAT GUIDE USERS ON MENSTRUAL AND SEXUAL HEALTH IN LOCAL LANGUAGES

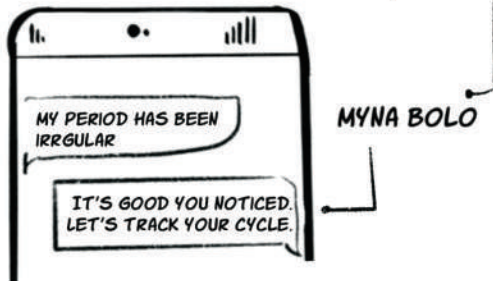
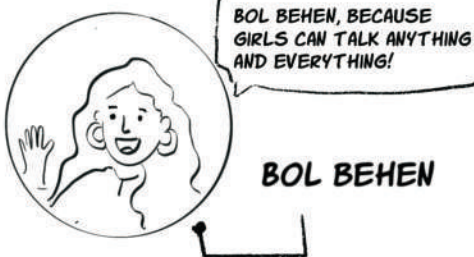

ETHICS, PRIVACY, AND THE FEM TECH BOOM

THE FEMTECH INDUSTRY INCLUDING MENSTRUAL HEALTH IS BOOMING, AND IS EXPECTED TO EXCEED TO 75 BILLION DOLLARS (2025). BUT DIGITAL HEALTH DATA IS INTIMATE.

MISUSE CAN LEAD TO DISCRIMINATION, TRACKING, AND LOSS OF REPRODUCTIVE AUTONOMY. EXPERTS URGE APPS TO ENSURE ETHICAL DATA HANDLING. ONGOING DEBATES HIGHLIGHT BIAS, UNEVEN ACCESS, AND LACK OF CULTURAL SENSITIVITY.

TOMORROW'S MENSTRUAL PRODUCTS WILL BE SMART, SUSTAINABLE, AND SELF-AWARE BUT MUST ALSO BE ETHICAL, INCLUSIVE, AND EMPOWERING

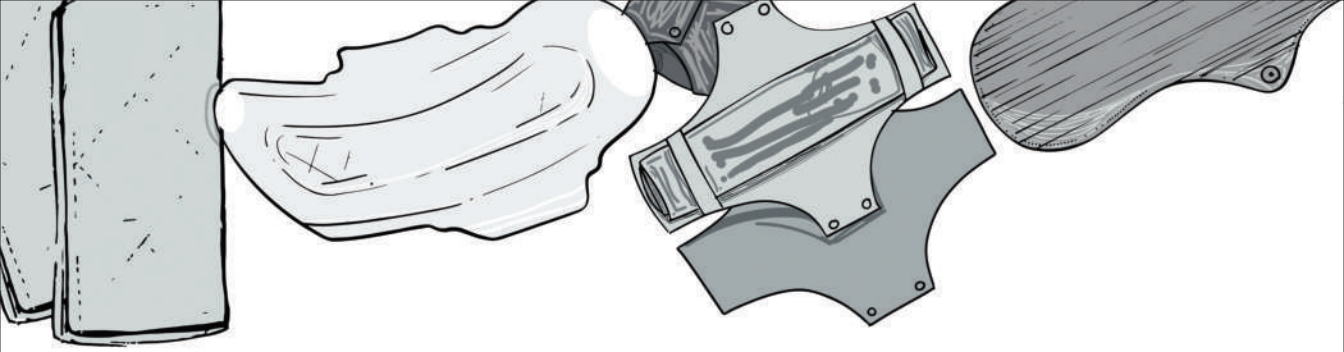

CONCLUSION

For as long as menstruating bodies have existed, so too have the methods, materials, and ingenuity to manage bleeding—quietly, resourcefully, and often invisibly. Over centuries, as societies shifted and gender roles evolved, so did the needs, aspirations, and expectations of those who menstruate. With each generation came new ways of managing periods—shaped by culture, necessity, innovation, and resistance.

This graphic novel offers a glimpse into that layered, dynamic journey in India. It traces the evolution of menstrual products from cloth and ash to period panties and menstrual discs—not merely as tools of hygiene or convenience, but as artifacts of social change, technological innovation, and personal empowerment. These products reflect how menstruation has moved from the margins to the mainstream, from whispered shame to platforms of dignity, choice, and advocacy.

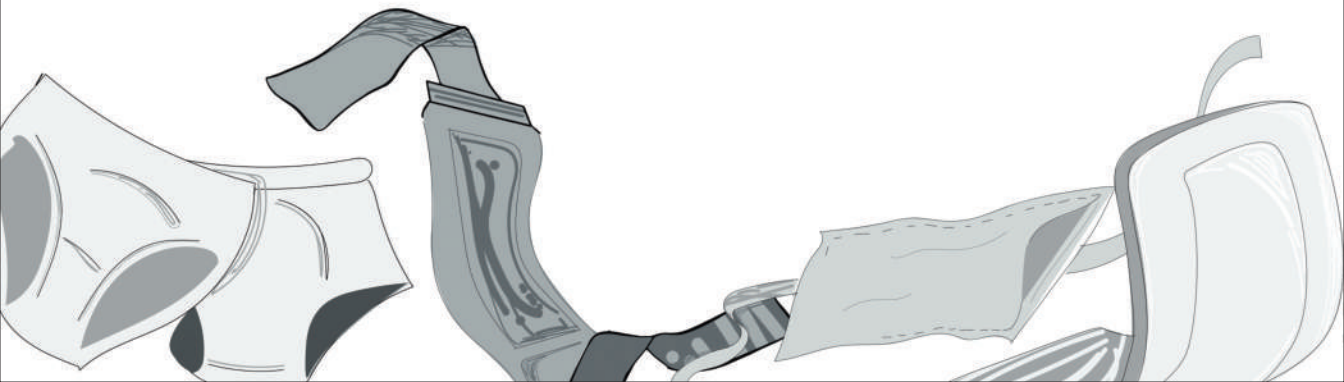



At the heart of this evolution lies a powerful truth: menstrual products are not just commodities; they are symbols of voice, visibility, and value. From the ingenuity of the “timepiece” to the engineering of the menstrual cup, every product in this timeline answers a call—sometimes for comfort, sometimes for affordability, sometimes for dignity.

Yet, innovation alone is not enough. The future of menstrual health must be shaped by those who use these products—not only engineers or entrepreneurs, but menstruators themselves. The person must remain at the centre: their body, their comfort, their context, their choice. Whether it’s environmental sustainability, cost, cultural preferences, or accessibility—user needs must continue to inform what gets made, how it’s distributed, and who gets to decide.

We hope this graphic novel serves as a living document—of memory, of movement, and of momentum. A reminder to social entrepreneurs, community leaders, funders, and policy makers that menstrual health is not a side issue. It is central to health, equity, and justice. Let this be a call to push boundaries—of product design, of inclusion, of imagination—and to always, always centre the person who menstruates.

ARUNDATI MURLIDHARAN
TANYA MAHAJAN

Founders
Menstrual Health Action
for Impact

KAILASH BRIJWASI
LAKSHMI MURTHY

Founders
Jatan Sansthan



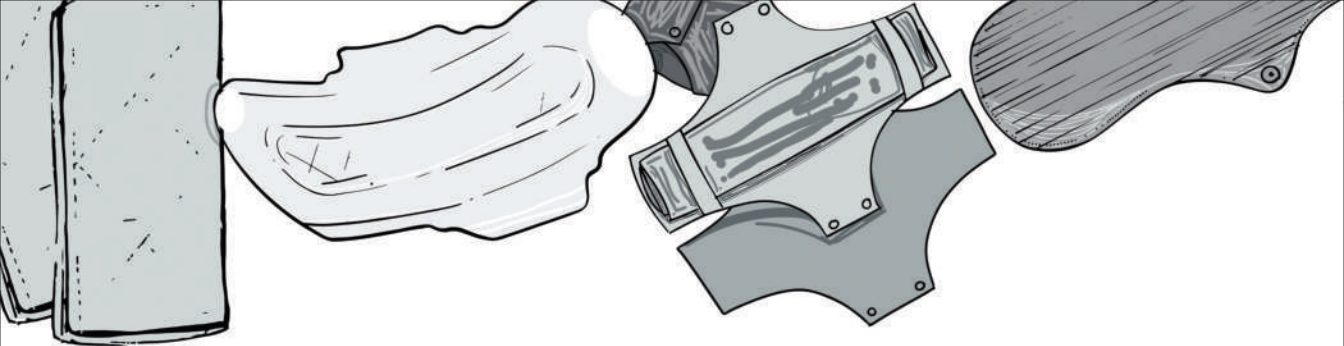

Contact Details:

Jatan Sansthan

5, Tirupati Vihar, Bhuwana Road, Near Celebration Mall,
Udaipur (Rajasthan), 313001

www.jatansansthan.org

info@jatansansthan.org

Menstrual Health Action for Impact (MHAi)

<https://www.menstrualhealthaction.org>

Info@menstrualhealthaction.org

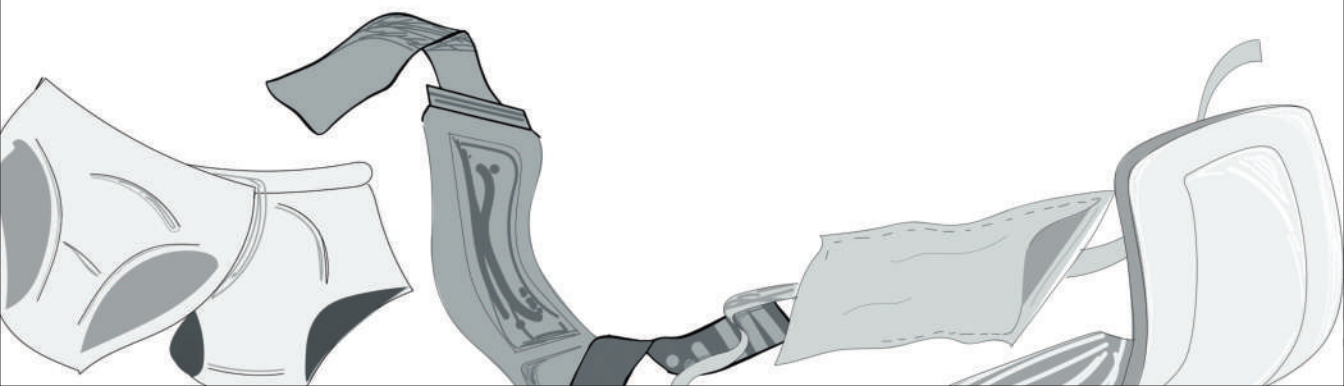



Websites:

Adira (Period Panties) - <https://myadira.com/>

Anandi Pads (Aakar Innovations) - <https://www.aakarinnovations.com/anandi>

Boondh - <https://boondh.co/>

Cresa - <https://cresagreentech.com/>

Ecofemme - <https://ecofemme.org/>

Fluus - <https://wearefluus.com/>

Goonj - <https://goonj.org/>

Jatan Sansthan - <https://jatansansthan.org/>

Jayaashree Industries - <https://en.wikipedia.org/wiki/>

Arunachalam_Muruganantham

Menstru AI - <https://www.menstruai.com/>

Padcare Labs - <https://www.padcarelabs.com/>

Papaya Pads - <https://www.papayapads.com/>

Q-Pad (Qvin) - <http://qvin.com/>

Saathi Pads - <https://saathipads.com/>

Sahayog - <https://www.sahayogindia.org/>

Saukhyam - <https://saukhyampads.org/>

SheCup - <https://shecup.com/>

Soch Green - <https://www.sochgreen.com/>

Tulipon - <https://tulipon.com/>

Vikalp Design - <https://vikalpdesign.com/>





**1970
TO
2025**

**STORIES ABOUT
MENSTRUAL PRODUCTS
IN INDIA**

**A GRAPHIC NOVEL ON THE EVOLUTION OF
MENSTRUAL PRODUCTS IN INDIA**

The narratives highlight how needs of
communities were understood and how
organisations and individuals responded

**Menstrual Health
Action for impact**

